



打造装备旗舰 引领纺织发展
CREATING A FLAGSHIP IN MANUFACTURING,
LEADING THE DEVELOPMENT OF TEXTILE INDUSTRY

SINCE **TONGDA** 1952 **山东同大纺机集团有限公司**

SHANDONG TONGDA TEXTILE MACHINERY(GROUP)CO.,LTD

JWF1211A /JWF1213 型梳棉机
CARDING MACHINE



CONTACT INFORMATION

Head office : Tongda industry park, Tongda Road, Changyi, Weifang, China
 Tel : 0086-532-68066288
 Fax : 0086-532-68066288
 Mobile: 0086-1815 3201 666
 E-mail: sales@china-tongda.com
 Skype: hrzhaowei
 Wechat ID: 18153201666
 Whatsapp: 0086-18153201666
 Website: www.china-tongda.com

产品规格与外观可能有变更 恕不预先通知。
 The specifications and external appearance of this unit are subject to change without prior notice.



高产高效的分梳系统

CARDING SYSTEM WITH HIGH PRODUCTION AND EFFICIENCY

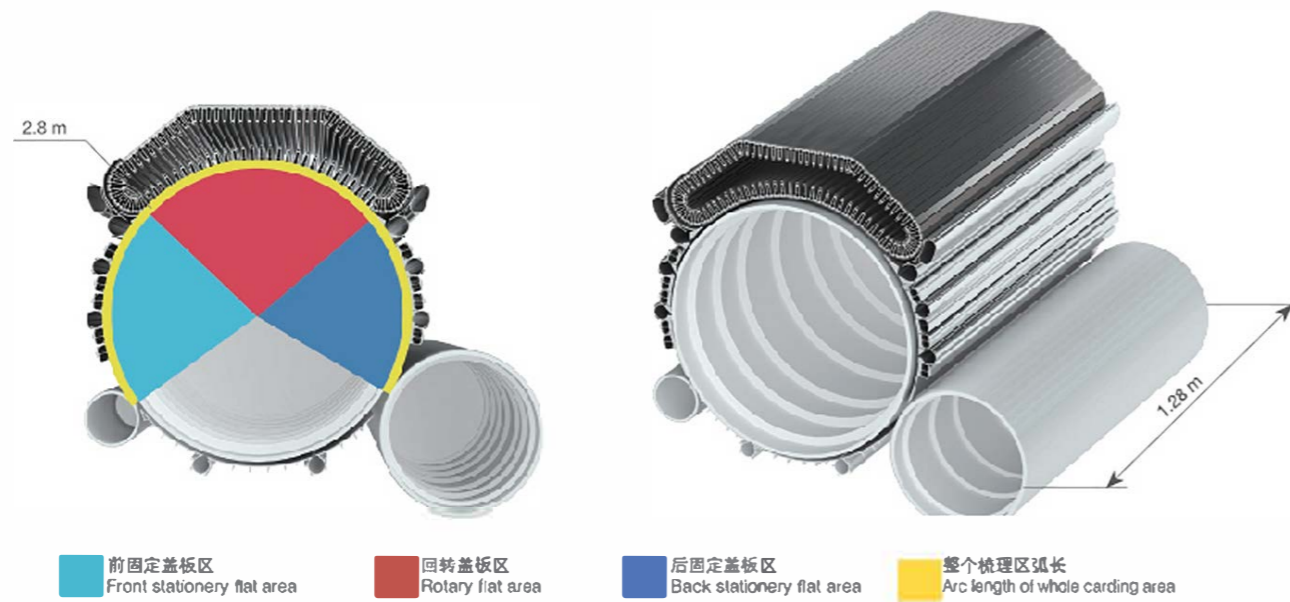

■ 前固定盖板区 Front stationary flat area
■ 回转盖板区 Rotary flat area
■ 后固定盖板区 Back stationary flat area
■ 整个梳理区弧长 Arc length of whole carding area

梳理弧长决定品质。2.8米最长梳理弧长，保证最佳质量。

The carding arc length decides the quality. Longest carding arc length of 2.8 meters ensures best quality.

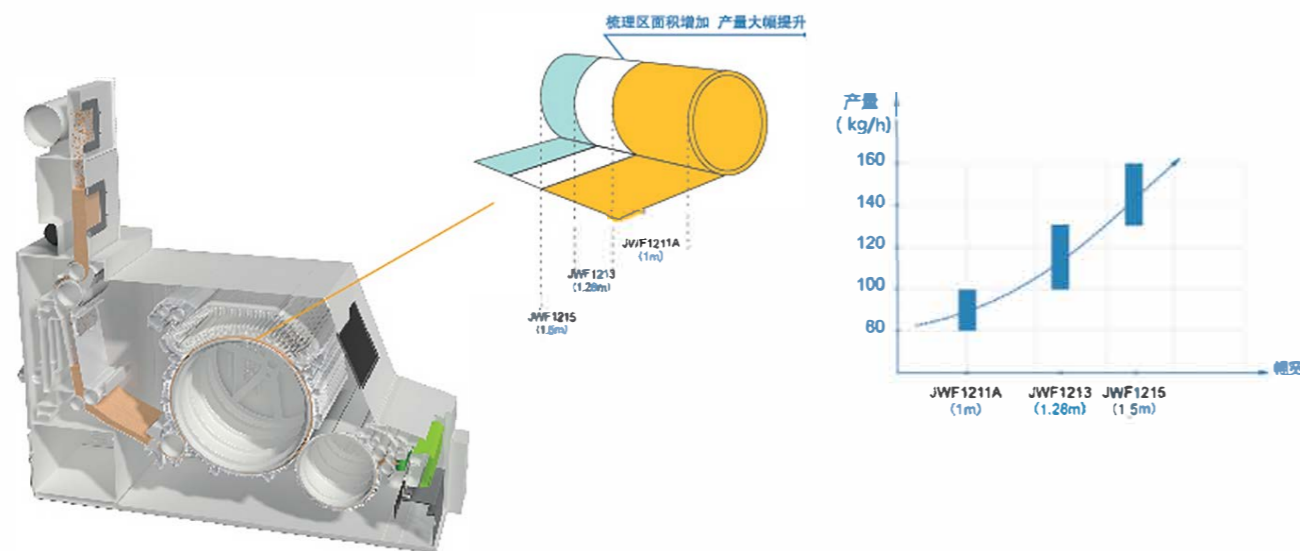

道夫 Doffer



锡林 Cylinder

整体铸造锡林、道夫及圆墙板，稳定性好，热膨胀系数小，确保高速高产主要分梳工艺隔距稳定。

Mono-block casting iron cylinder, doffer and side wall ensures good stability and low thermal expansion coefficient. The carding technical gauge is stable even when machine runs at high speed, ensuring the high production.

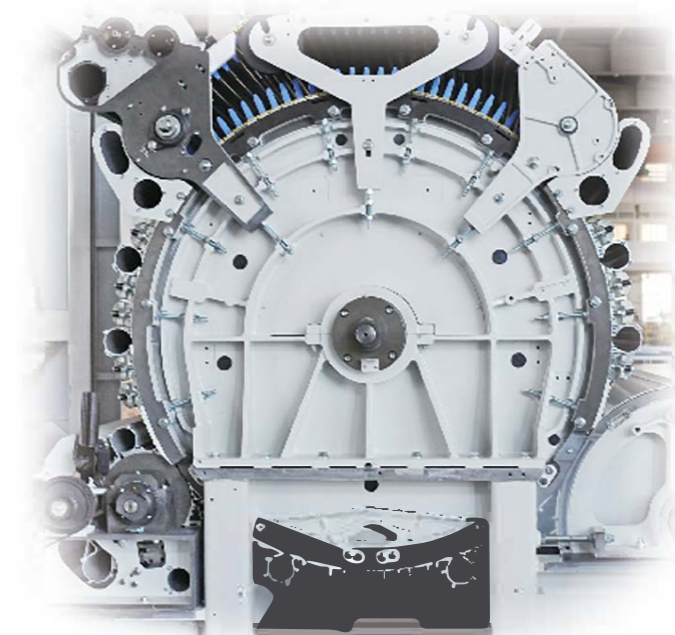

圆墙板 Side wall

阶梯式的钢板焊接整体机架，简洁的机械结构，特殊的加工工艺，保证了整机主要部件和隔距的稳定性、一致性。

The stepped entity frame welded by steel plate is characterized by its flexible mechanism and its special processing technology, ensuring the major gauge stable and uniform.

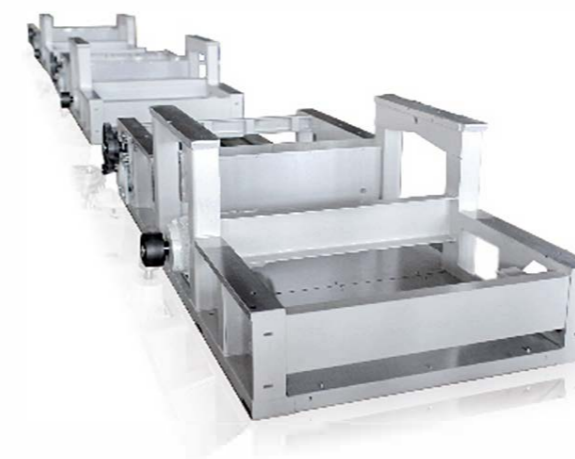

可靠稳定的质量保证

STABLE AND RELIABLE QUALITY GUARANTEE

新型的传动形式 New type of driving method

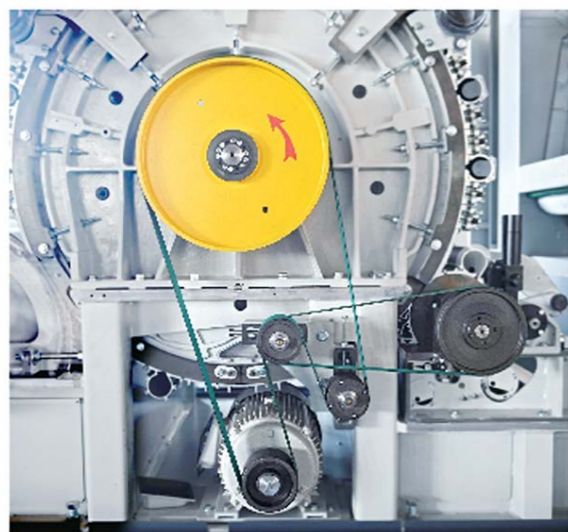

锡林刺辊采用大扭矩电机，启动平稳、运行可靠。
Cylinder and licker-in adopt high torque motor, featured by stable start and reliable rotary.

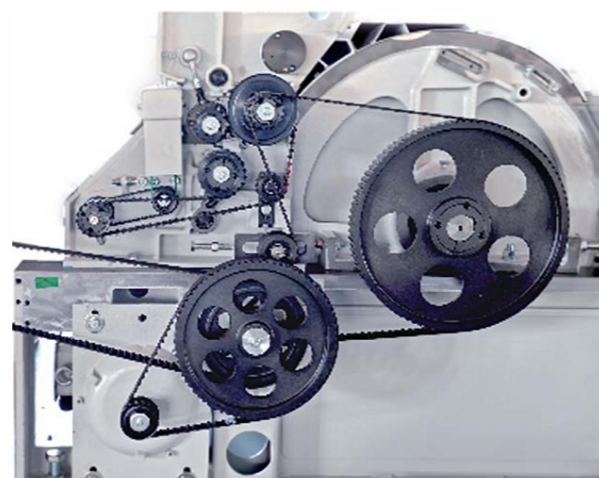

道夫采用变频电机传动，确保低速、高速及转换时的稳定。

Doffer is driven by vector motor to ensure stability in low speed, high speed and speed conversion.

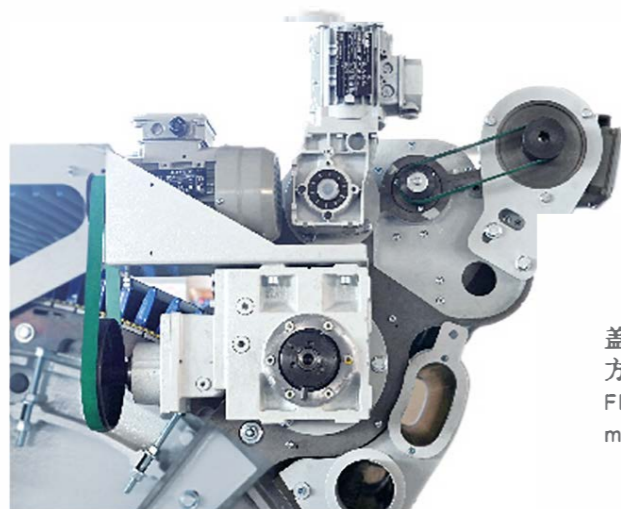

盖板及盖板刷辊单独变频电机传动，工艺速度调整方便。

Flat and flat brush roller is driven by independent vector motor for convenient speed adjustment



高效的盖板清洁单元 Leaning unit with high efficiency

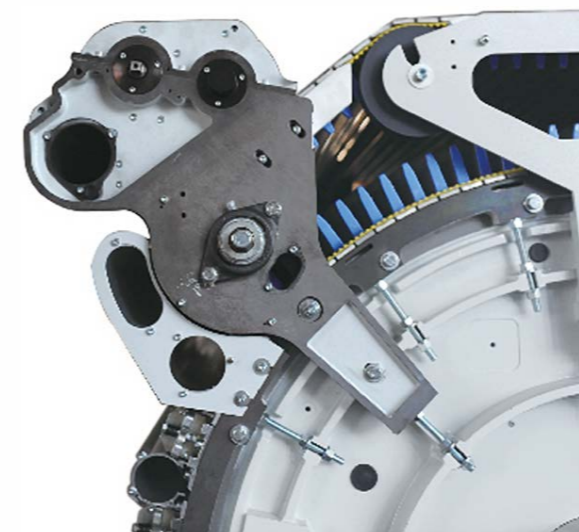

- ☆ 刷辊采用单独变频电机传动，根据适纺品种的不同设定相应速度。
- ☆ 刷辊与回转盖板采用可调式隔距设计，实现回转盖板的深度清洁。
- ☆ 刷辊和清洁辊相对位置及隔距的完美设计，确保盖板花及时转移。
- ☆ 新型清洁吸罩与流体力学的完美结合，降低风阻，盖板花吸除顺畅。

- ☆ Brush roller adopts the independent motor and inverter. The step-less speed adjustment ensures the flats cleanliness by setting different speeds according to materials.
- ☆ The gauge adjustable design of the brush roller and the revolving flats ensures the deep cleaning of the revolving flats
- ☆ The optimized relative position and gauges between the brush roller and cleaning roller ensures the timely removed of the flat cotton fly.
- ☆ The new clean suction hood with perfect fluid mechanics can reduce the drag and suck flat fly smoothly.



新型刺辊分梳系统

NEW TYPE OF LICKER-IN CARDING SYSTEM

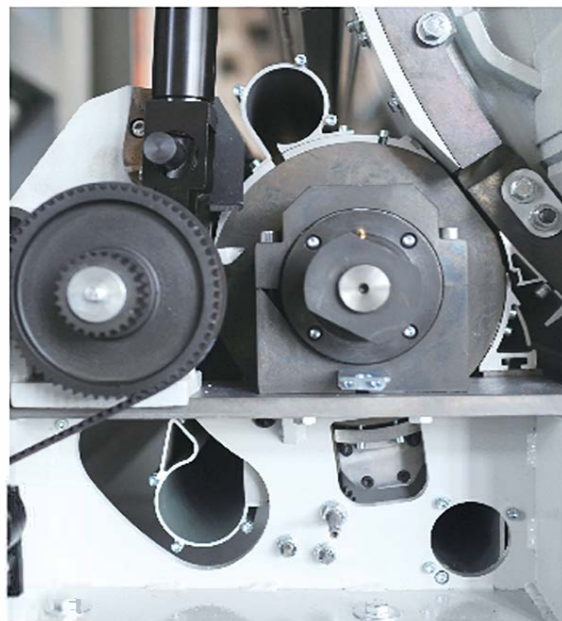

- ☆ 刺辊设有两个落杂区，落杂区长度机外可调。
- ☆ 设两把除尘刀、预分梳板，高效去除杂质和短绒。
- ☆ Licker-in is designed with two noil area whose length is adjustable outside of machine.
- ☆ It is designed with two sets of mote knife, pre-carding segment for efficiently removal of trash and staple

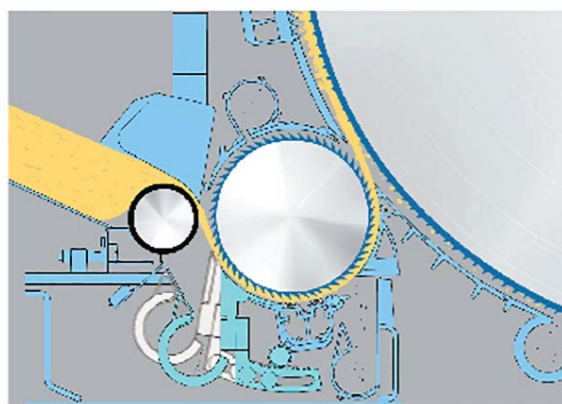
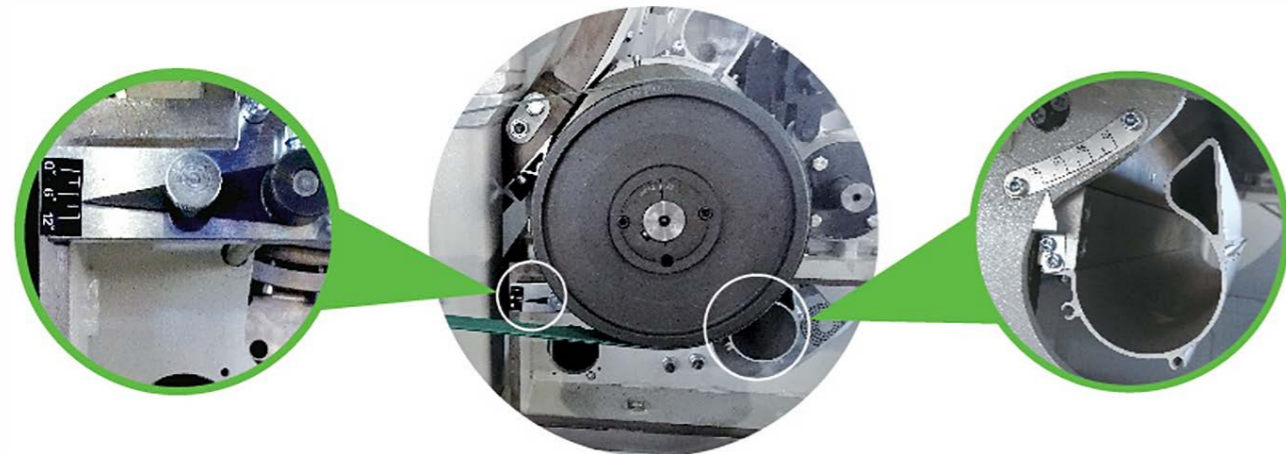

根据纺纱的不同原料、品种、品质要求，灵活调整落杂区长度。

- ☆ 第一落杂区弧长绕刺辊中心自由调整。
- ☆ 第二落杂区根据需求适当调整舌板角度。

Noil area length is adjusted flexibly according to quality, type of material.
 ☆ Arc length of the first noil area is adjusted freely around licker-in center.
 ☆ Angle of tongue plate in the second noil area is adjusted according to requirement.



滤尘系统

DUST FILTERING SYSTEM

稳定的吸风和气流是优质梳理质量的保障

Stable air suction and airflow gurantee the carding quality

新型滤尘系统采用流线型结构设计，更加符合气流运动学规律，减少风阻，节能降耗。

The new dust-filtering system adopts the streamline structure and is more in line with the flow kinematics, which can reduce wind resistance as well as save energy and reduce cost.

铝合金封闭式大漏底，拆装方便，强制吸尘，外形美观。

Aluminum-alloy enclosed undercase, easy dismantling. Suction is coercive and its profile is beautiful.

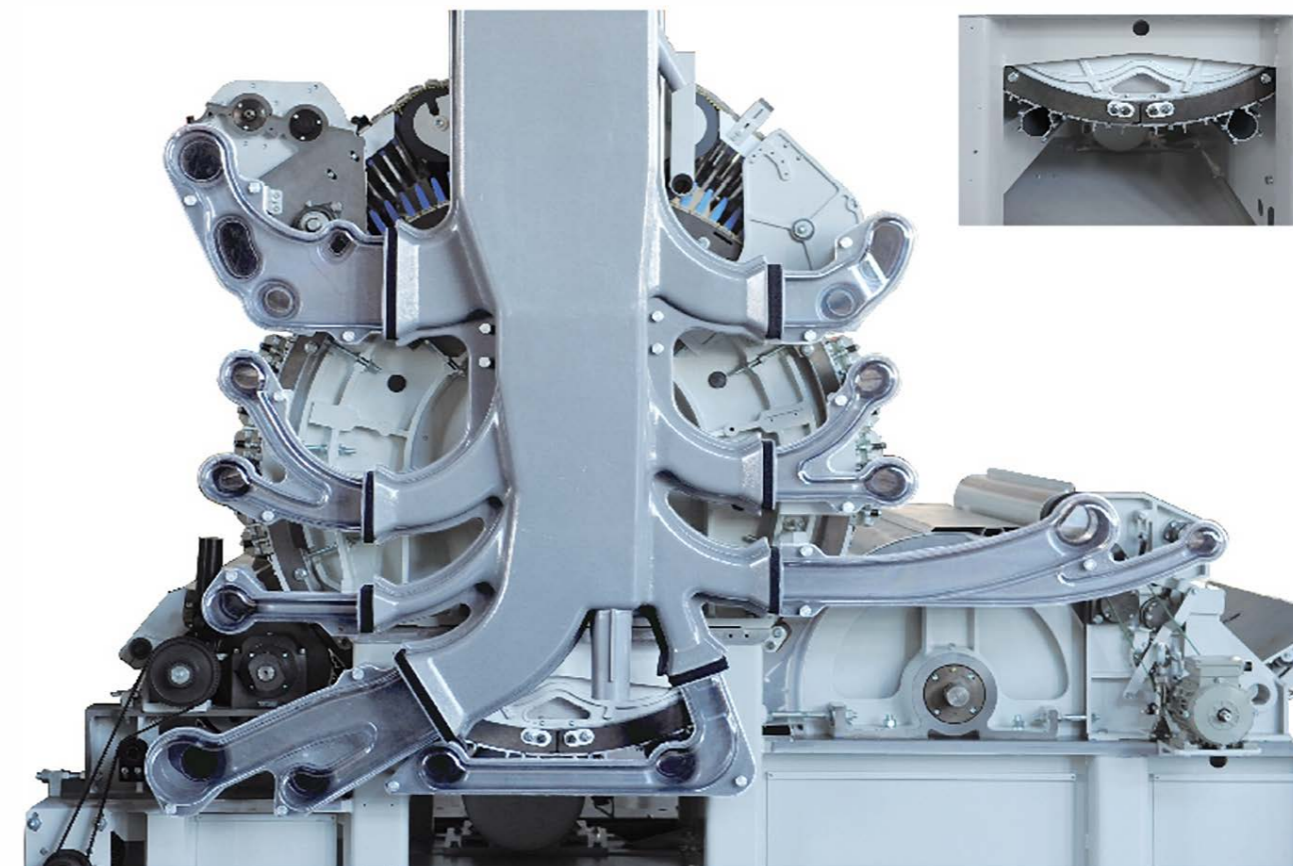

可视的滤尘管道，光滑流畅，维修方便，多点连续吸，压力连续监测，吸尘杂效果好。

The visible filtering pipes, sleek and smooth, are easy for maintenance. The multi-point continuous suction and continuous pressure testing contribute to the good filtering effects.

模块化设计-操作方便 维护快捷

MODULAR DESIGN-EASY OPERATION AND MAINTENANCE



固定盖板模块 Modular of stationery flats

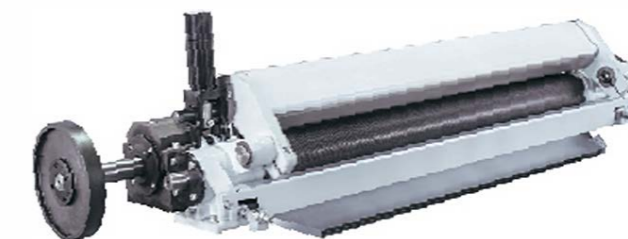

给棉模块 Modular of feed unit

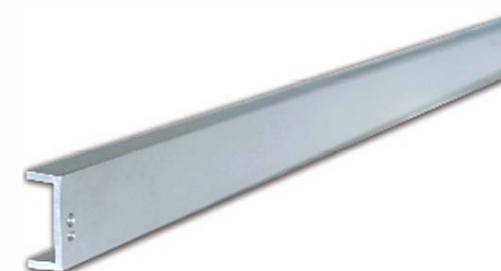

罩板模块 Modular of al-alloy sheet



棉网清洁器模块 Modular of web cleaner

☆ 特殊材料的铝合金回转盖板件，平整度好，重量轻，运行稳定。

☆ 通过两条齿形带连续引导，不需其他紧固件，拆卸、安装便捷，维护方便。

☆ Aluminum alloy rotary flat body is made by special material, with the characteristics of good flatness, light weight, stable operation

☆ It is guided by two tooth belts without need of other fasten parts, so it is easy for mantle, dismantle and maintenance

☆ 双联固定盖板、棉网清洁器和罩板采用铝合金型材，良好的针尖平整度，隔距调整方便，保证纤维的梳理更加充分、细致。

☆ 模块化设计，可根据纺纱品种、工艺要求进行灵活配置。

☆ Duplex stationery flats, web cleaners and cover plates adopt aluminum alloy material. The fine needle flatness and easily adjustable gauge guarantee the fine and intensive material carding.

☆ Modular design realizes flexible replacement to meet different technical requirements based on various material and guarantees excellent product.

新型混合环自调匀整系统 NEW TYPE MIXED LOOP AUTO-LEVELLER SYSTEM

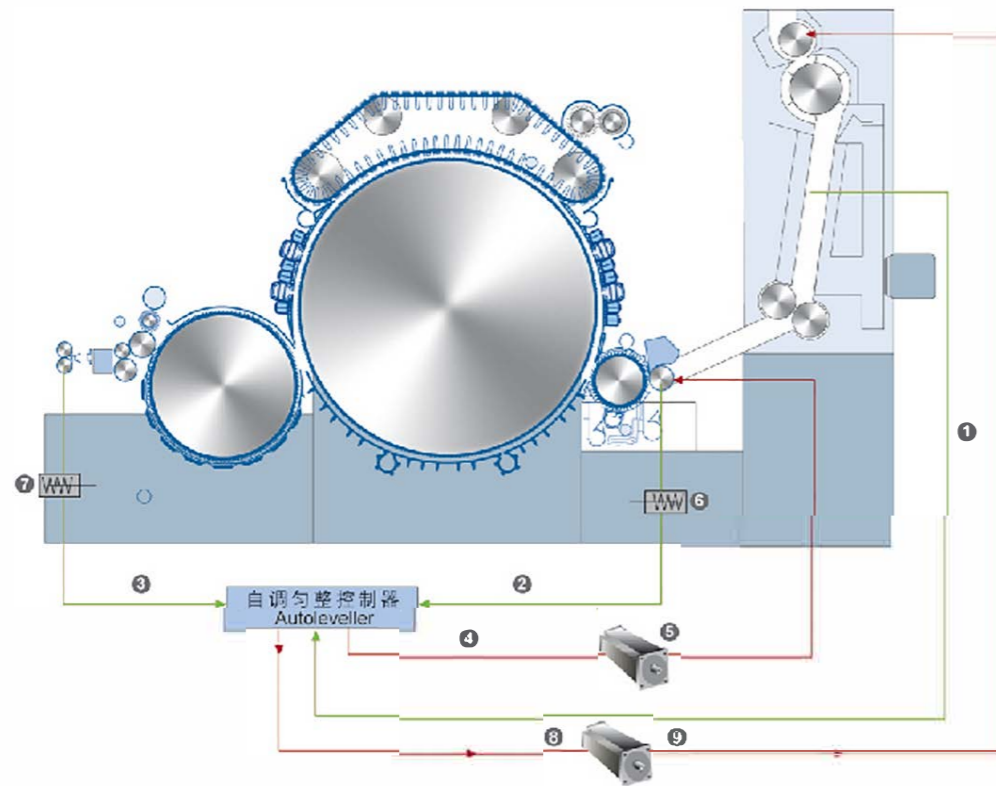

1. 棉箱压力监测
 2. 检测喂入棉层检
 3. 检测输出棉条
 4. 调整喂棉罗拉
 5. 喂棉罗拉驱动器
 6. 短片段控制传感器
 7. 长片段控制传感器
 8. 调整棉箱喂棉罗拉
 9. 喂棉罗拉驱动器
1. Detect chute pressure
 2. Detect feed batt
 3. Detect sliver delivery
 4. Adjust feed roller
 5. Feed roller driver
 6. Short term control sensor
 7. Long term control sensor
 8. Adjust feed roller
 9. Feed roller driver

长短片段自调匀整器 Long-short term autoleveller

新型混合环自调匀整器，专用于顺向喂棉结构，利用高精度涡流式非接触型传感器检测纤维厚度的变化，实行短片段控制，利用棉条定量变化实行长片段控制，组成稳定的混合环控制方式。配合变频电机传动系统，提高传动精度，确保稳定的棉条CV值。

The new mixed loop auto-leveller, exclusively used for the directional feeding design, can detect the batt thickness variation by use of precision vortex non-contact sensor to control fiber in short term and realize the control of fiber in long term via detecting sliver count variation, reaching the open-close loop control. The inverter motor also enhances the driving precision and stable sliver CV value.

新型检测及保护系统 NEW TYPE DETECTING AND PROTECTING SYSTEM

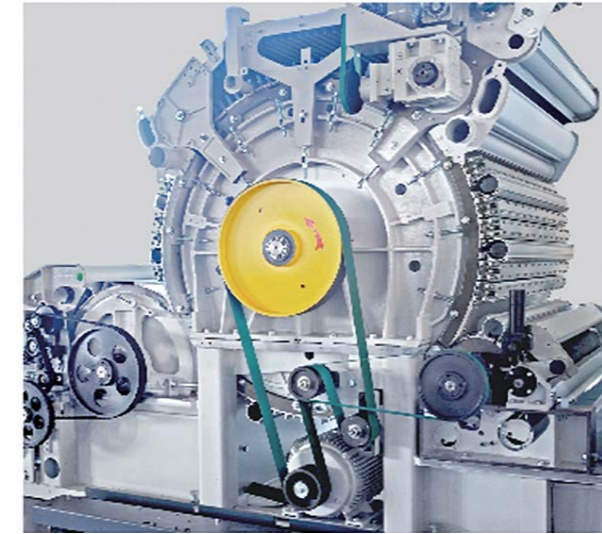

给棉金属检测的应用，确保无金属异物喂入。
Metal detecting device to deduct metal during cotton feeding.

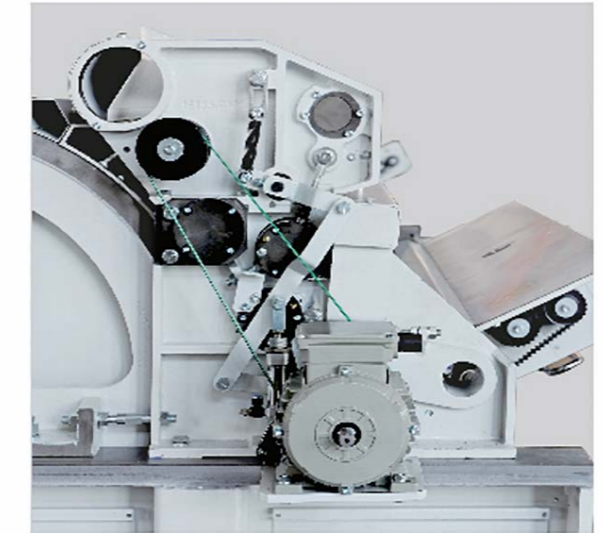

上下轧辊防缠检测机构，有效保护传动带。
Anti-winding detecting mechanism of the upper and lower roller effectively protects the driving belt.

棉结在线检测装置（选配） NEP ONLINE-MONITORING (Option)

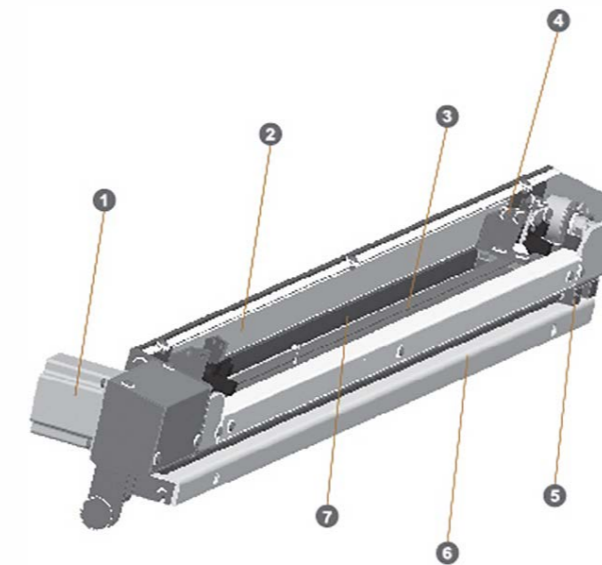

棉结在线检测装置，对棉结进行实时检测及统计。
Neps on-line detecting device makes real-time monitoring and statistics to neps.

本装置是用于梳棉机在线检测棉网中棉结杂质的传感系统，通过左右往复运动的照相机对道夫棉网进行拍照，对图像进行精确的分析与处理，及时反映条中棉结杂质数量，并将检测结果显示在梳棉机显示屏上。

The nep online-monitoring device, a sensing system used on the carding machine, can take photos of the doffer cotton web via the process the image accurately, and reflect timely detecting of the neps quantity of the sliver, thus the results are shown on the touch screen of the carding machine.

- | | |
|----------------|---|
| 1. 步进电机 | 1. Stepping motor |
| 2. 透明玻璃 | 2. Transparent glass plate |
| 3. 往复滑块、导轨及传动带 | 3. Reciprocating slider, Rail and Driving |
| 4. 照相机及闪光灯 | 4. Came & Flash |
| 5. 推拉滑块和导轨 | 5. Push-and -pull slider & Rail |
| 6. 固定横梁 | 6. Fixed beam |
| 7. 底座箱体 | 7. Base cabinet |

机外高速切条 SLIVER-CUTTING WITHOUT

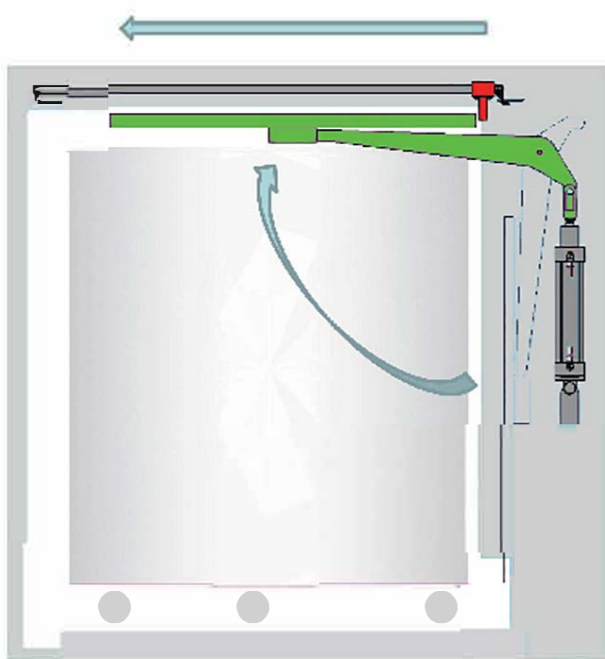

- ☆ 高速机切条，换筒时道夫不降速，生条质量平稳，节约原料。
- ☆ 相比回转式自动换筒，结构简洁易维护，占地面积节约33%
- ☆ The sliver cutting and can-changing do not require doffer speed decrease, realizing stable sliver count and saving material.
- ☆ The linear automatic can-changer coiler is easy to maintain and saves space by 33% compared with rotary type.



独特的六点隔距及新型的皮圈导棉 PARTICULAR 6-POINTS GAUGE AND NEW TYPE OF CROSS APRON

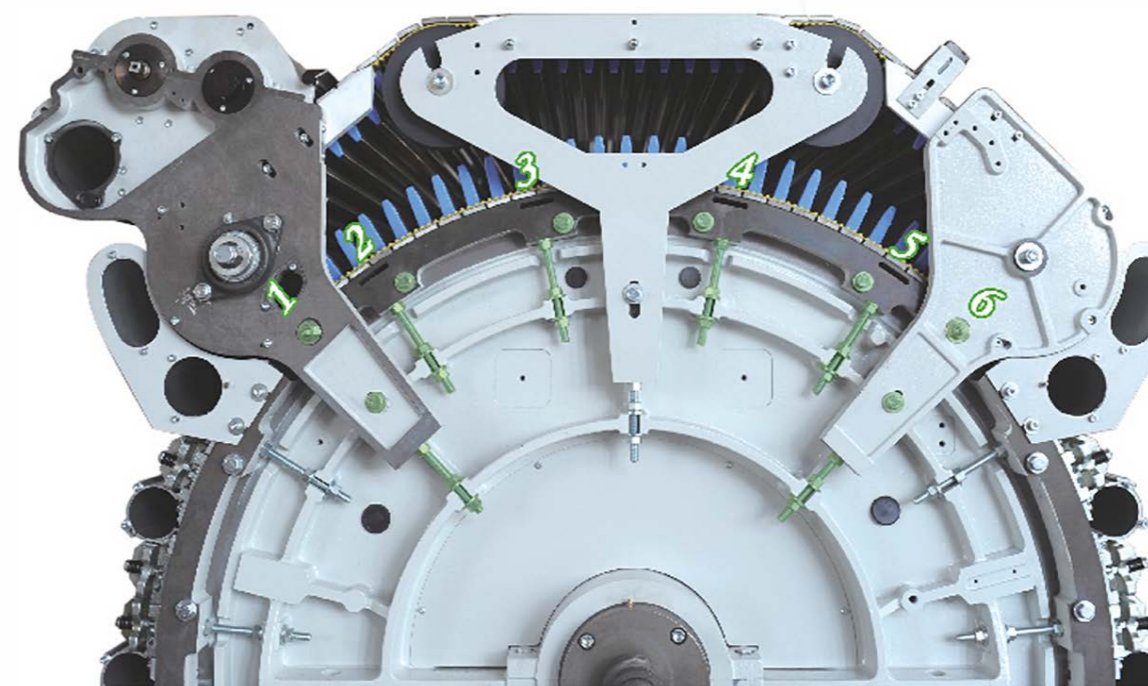

- ☆ 整个机器工作宽度上梳理隔距的精确程度是梳理效果的决定因素。6点隔距检测，使梳理隔距在运转中始终保持精确不变。无级调速，配合匀整系统和新型前环检测，使生条均匀度得到大幅提升。
- ☆ Precision degree of gauge on whole working width is the decisive factor for carding efficiency. 6 - point detection ensure constant carding gauge during operation. Stepless speed regulation, levelling system and new type detecting eyetem can greatly increase sliver irregularity.



- ☆ 新型大压辊及皮圈导棉装置，采用无齿轮平皮带传动，结构紧凑，保证棉条可以高速稳定输出。



- ☆ New big calendar roller and type of cross apron adopts flat belt for drive with compact structure, to ensure stable sliver output in high speed

工艺先进性

ADVANCED MANUFACTURABILITY

高效-节能

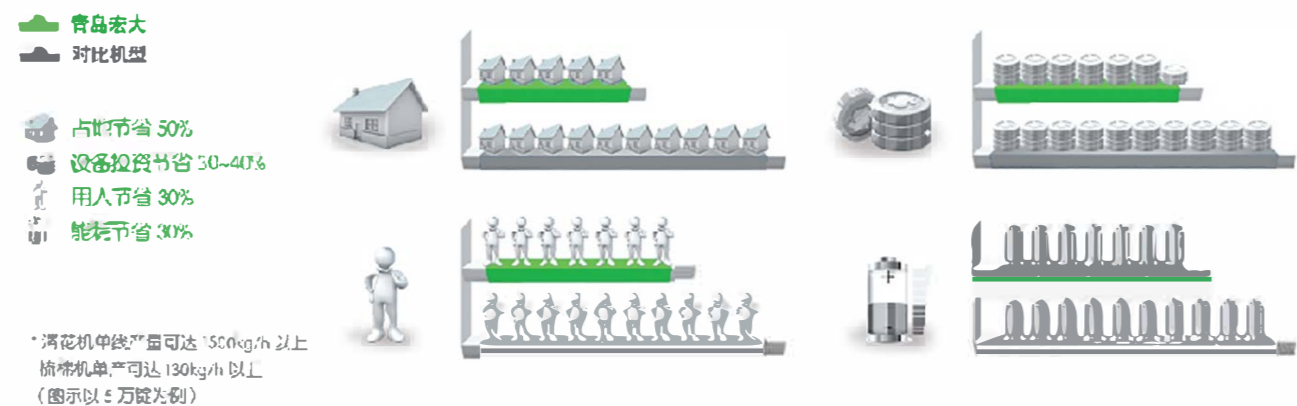
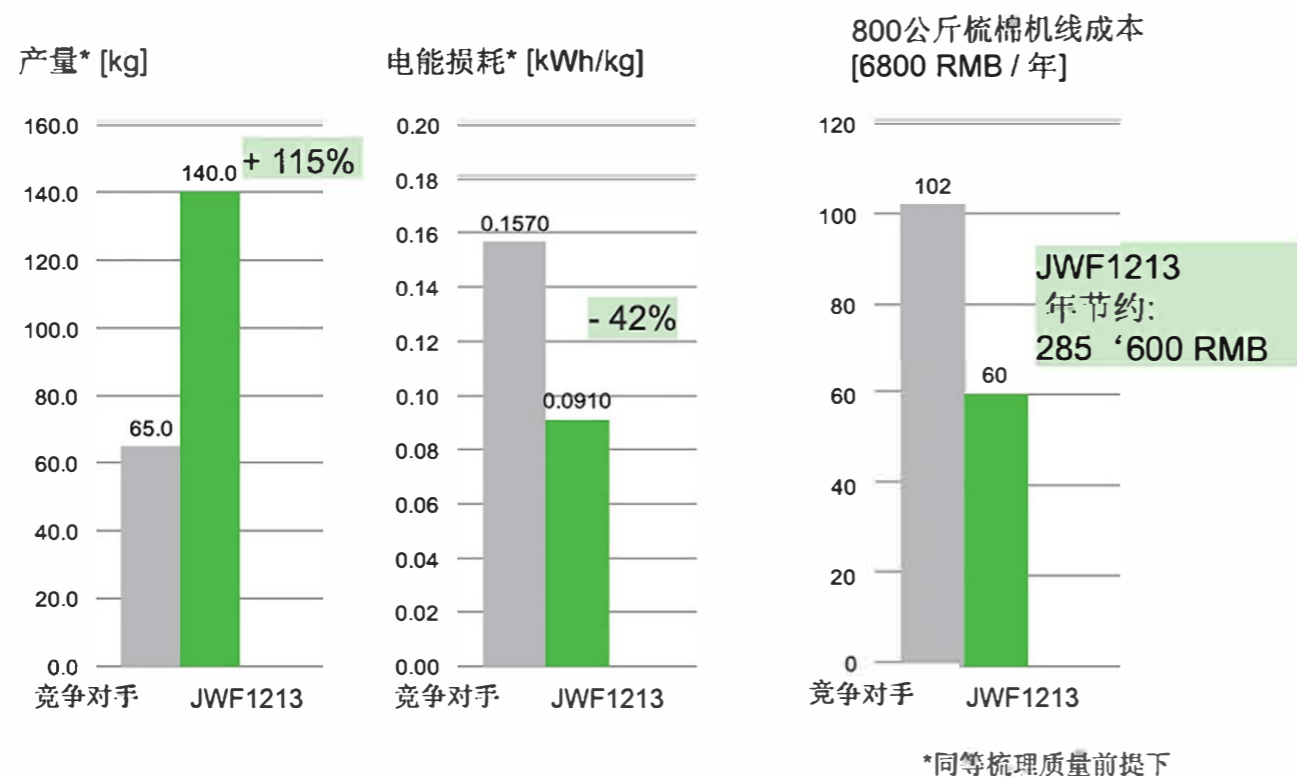

棉结去除率

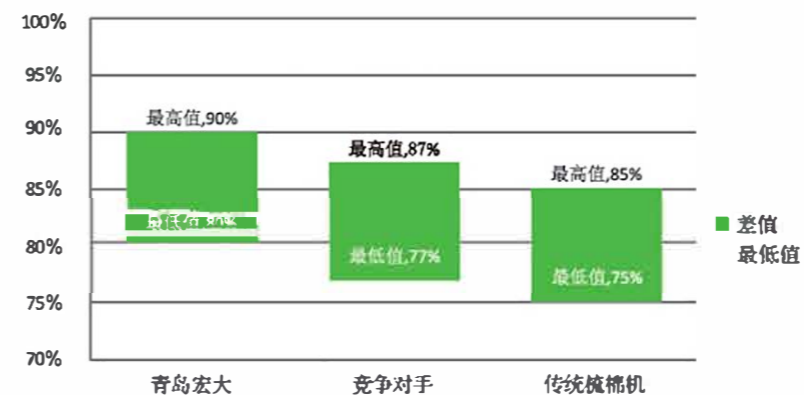

杂质去除率

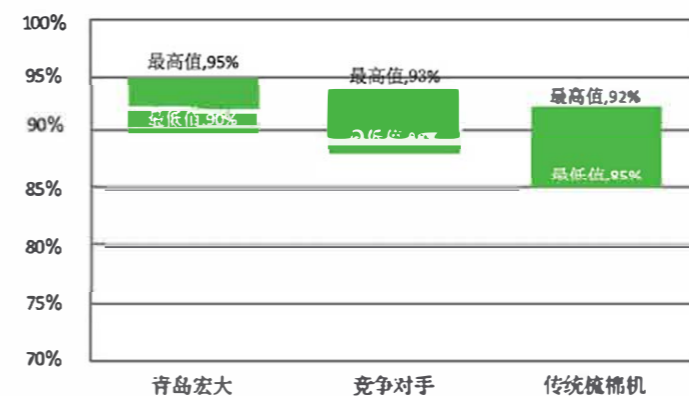

短绒增长率

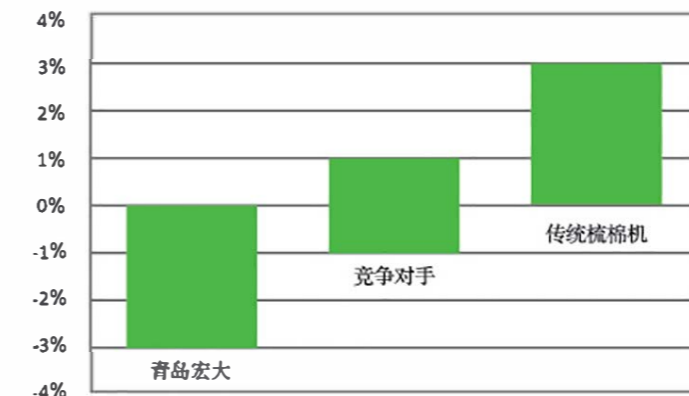

☆ 本数据来源于客户正常生产中的信息，质量指标与竞争对手的相比较，从中可以看出JWF1211A、JWF1213去除棉结的能力、除杂效率等各项指标都优于市场上同等水平的梳棉机。

☆ All data come from user during production. Compared with our competitors, our quality index such as neps removal ability and dust removal efficiency of JWF1211A, JWF1213 are better than that of the same level of carding machine on the market.

结构示意图

STRUCITION FIGURE

梳理部分 CARDING SECTION

- 01 刺辊第一除尘刀
Licker-in 1st mote knife
- 02 刺辊第二除尘刀
Licker-in 2nd mote knife
- 03 刺辊分梳板
Licker-in segment
- 04 刺辊
Licker-in
- 05 后固定盖板
Back stationery flat
- 06 锡林封闭漏底
Cylinder enclosed undercase
- 07 锡林
Cylinder
- 08 铝合金回转盖板
Al-alloy rotary flat
- 09 前固定盖板
Front stationery flat
- 10 道夫封闭漏底
Doffer enclosed undercase
- 11 道夫
Doffer
- 12 三罗拉清洁辊
Three roller clearer
- 13 三罗拉
Three roller

棉箱部分 CHUTE FEEDER SECTION

- 14 上棉箱
Upper chute feeder
- 15 给棉罗拉
Feed roller
- 16 给棉板
Feed plate
- 17 开松辊
Open roller
- 18 静压箱
Statistic pressure case
- 19 下棉箱
Lower chute feeder
- 20 循环风机
Circling fan
- 21 棉箱输出罗拉
Chute output roller
- 22 导料槽
Material slot
- 23 电气控制柜
Control cabinet

圈条器部分 COLIER SECTION

- 24 圈条器
Coiler

匀整部分 LEVELING SECTION

- 25 顺向给棉板
Directive feed plate
- 26 给棉罗拉
Feed roller
- 27 皮围导棉装置
Cross apron
- 28 大压辊
Big calender

滤尘部分 DUST FILTERING SECTION

- 29 前车肚吸点
Front undercard suction point
- 30 锡林漏底吸点
Cylinder undercase suction point
- 31 刺辊第二落杂区吸点
Licker-in 2nd noil suction point
- 32 刺辊第一落杂区吸点
Licker-in 1st noil suction point
- 33 刺辊放气罩吸点
Licker-air bleet suction point
- 34 后下棉网清洁器吸点
Rear /lower web cleaner suction point
- 35 后上棉网清洁器吸点
Rear /upper web cleaner suction point
- 36 后盖板杂质吸点
Rear flat trash suction point
- 37 盖板花吸点
Flat fly suction point
- 38 盖板飞花吸点
Flat trash suction point
- 39 前盖板杂质吸点
Front flat trash suction point
- 40 前上棉网清洁器吸点
Front/upper web cleaner suction point
- 41 前下棉网清洁器吸点
Front/lower web cleaner suction point
- 42 三罗拉清洁吸点
3-rollers suction point
- 43 喇叭口吸点
Horn mouth suction point
- 44 圈条器吸点
Coiler suction point
- 45 主动轴吸点
Driving shaft suction point

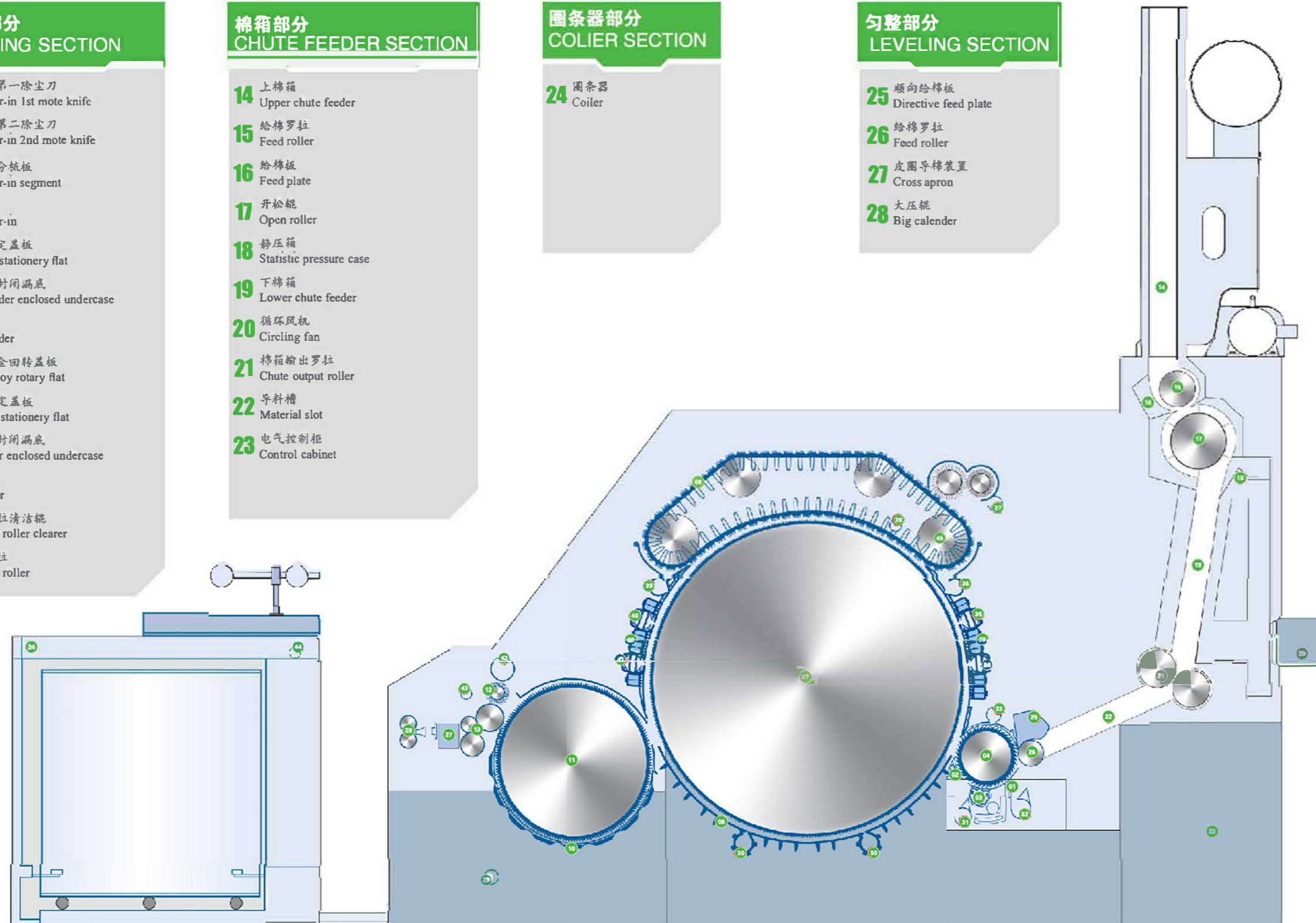

新型一体化棉箱 TYPE OF CHUTE FEEDER



主要规格 specifications

喂棉箱	JWF1173
棉箱宽度 (毫米)	950
给棉罗拉直径 (毫米)	Φ172
开松辊直径 (毫米)	Φ292
开松辊转速 (r/min)	850/1150
输出罗拉直径 (毫米)	Φ156
装机功率 (千瓦)	2.05
外形尺寸 (长x宽x高) (毫米)	700x1550x2995
机器净重 (公斤)	约 900
Working width (mm)	950
Feeding roller dia. (mm)	Φ172
Opening roller dia.(mm)	Φ292
Opening roller speed (r/min)	850/1150
Output roller dia. (mm)	Φ156
Installed power (kW)	2.05
Boundary dimension(LxVxH)(mm)	700x1550x2995
Net weigh (kg)	About 900

喂棉箱	JWF1177
棉箱宽度 (毫米)	1210
给棉罗拉直径 (毫米)	Φ172
开松辊直径 (毫米)	Φ292
开松辊转速 (r/min)	850/1150
输出罗拉直径 (毫米)	Φ156
装机功率 (千瓦)	3.4
外形尺寸 (长x宽x高) (毫米)	700x1810x2995
机器净重 (公斤)	约 1100
Working width (mm)	1210
Feeding roller dia. (mm)	Φ172
Opening roller dia.(mm)	Φ292
Opening roller speed (r/min)	850/1150
Output roller dia. (mm)	Φ156
Installed power (kW)	3.4
Boundary dimension(LxVxH)(mm)	700x1810x2995
Net weigh (kg)	About 1100

- ☆ 新型棉箱储棉容量大, 供棉稳定, 有效改善条干均匀度及重量不匀率。配棉头采用开启式视窗, 便于维护。
- ☆ 棉箱采用机内循环风, 筵棉更均匀稳定。采用新型密封结构, 有效防止塞花。
- ☆ 给棉板采用弹簧加压, 弹性握持纤维, 与给棉罗拉之间的距离可根据棉层的厚度自动调节。

- ☆ New type of chute feeder, with big capacity, supply cotton stably and improves sliver evenness and weight regularity efficiently. The topchute feeder is equipped with the open-type view-window and easy to maintain.
- ☆ Air is circling inside the chute feeder, make batt more even and stable. The new type sealing structure avoids cotton blocks efficiently.
- ☆ Feeding plate is pressurized by spring so fiber is hold elastically. Distance between feeding plate and feeding roller is automatically adjusted according to batt thickness.

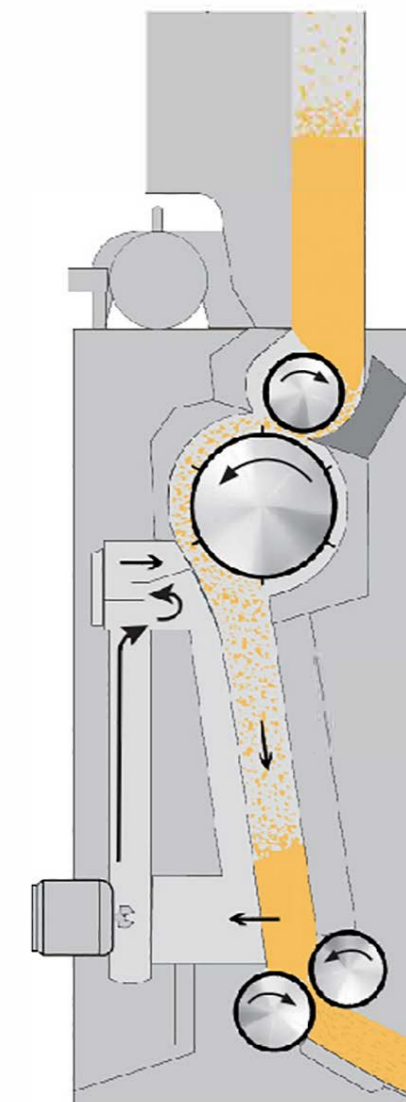

结构示意图 Construction figure

主要规格 SPECIFICATIONS

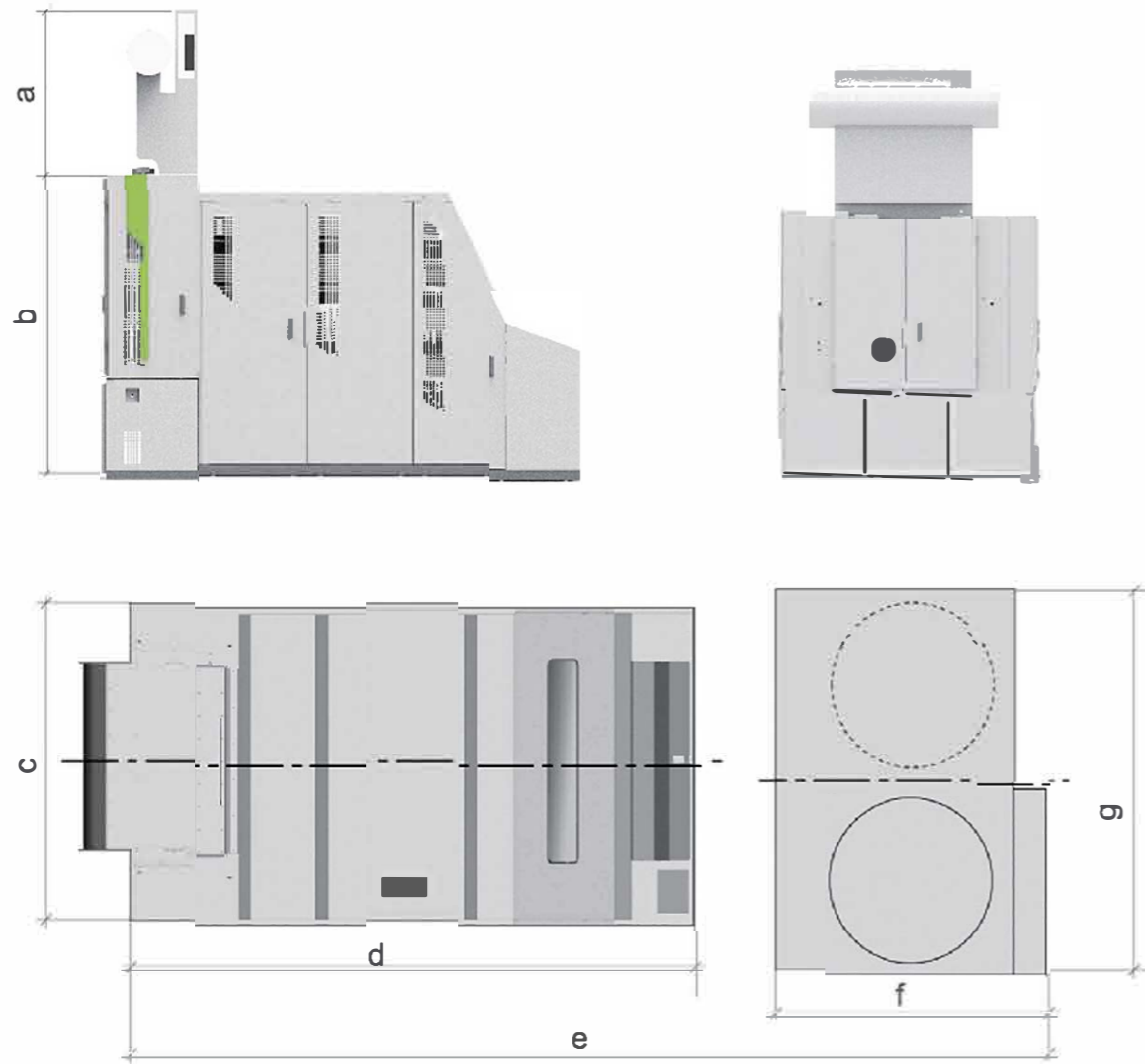

机型 / Type	a	b	c	d
JWF1211A	1200	2325	1980	3620
JWF1213	1395	2325	2240	3620

机型 / Type	e	f	g
Φ600 自动	5250	1130	1552
Φ1000 自动	5825	1751	2480

机型	Type	JWF 1211A	JWF 1213
适用范围	Application	本机适用于纤维长度22~76毫米的纯棉、化纤及其混纺 Application applicable to chemical fiber pure cotton in length from 22~76mm and other blended material	
最高产量 (公斤/小时)	Max. Actual output (kg/h)	100	160
最高出条速度 (米/分)	Max. Sliver delivery speed (meter/min)	300	320
棉条定量 (克/米)	Sliver count(g/m)	3~7	3.5~10
喂棉重量 (克/米)	Feed weight(gram/meter)	400~1000	400~1300
工作幅宽 (毫米)	Working width(mm)	1000	1280
总牵伸倍数	Total draft folds	60~300	38~370
刺辊工作直径 (毫米)	Licker-in working diameter(mm)	Φ250	Φ250
道夫工作直径 (毫米)	Doffer working diameter(mm)	Φ706	Φ706
道夫工作速度 (转/分)	Doffer working speed(rpm)	4.3~84	4.3~84
锡林工作直径 (毫米)	Cylinder working diameter(mm)	Φ1288	Φ1288
锡林工作速度 (转/分)	Cylinder working speed(rpm)	347~477	347~477
回转盖板根数 (工作盖板/盖板总数)	Pieces of rotary (working flat/total flats)	30/84	30/84
盖板速度(毫米/分)	Flat speed (mm/min)	70~408	70~408
附加梳理件	刺辊分梳板	Licker-in carding segment	2根 (Pieces)
	前固定盖板	Front stationery flats	8根 (Pieces)
	后固定盖板	Back stationery flats	10根 (Pieces)
棉网清洁器	前3后3	Web cleaner	纺棉 (Cotton)
	前2后2	Web cleaner	纺化纤 (Chemical fiber)
连续吸尘风量 (米³/小时)	Continuous air suction volume(m³/hour)	4000	4200
出口静压 (帕)	Statistic pressure at exit(pa)	-800	-800
压缩空气压力 (公斤/厘米²)	Compressed air pressure (kg/cm²)	6~7	6~7
空气消耗 (米³/小时)	Compressed air consumption(m³/h)	0.5	0.5
总装机功率 (千瓦)	Total power installation(kW)	9.24	13.79
安全罩形式	Safety cover type	全封闭 Totally enclosed	全封闭 Totally enclosed
占地面积 (长x宽) (毫米)	Land occupation (L x W)(mm)	5825X2480x3525 (Φ1000)	5825X2480x3720 (Φ1000)
机器净重 (公斤)	Machine net weight(kg)	(About) 约 7200	About 约 8000