

CHOICE[®]
HIGH TECHNOLOGY

TAIZHOU ROSEW MACHINERY CO.,LTD.

ADD:NO.188 DEVELOPING ZONE , JIAOJIANG,
TAIZHOU CITY, ZHEJIANG PROVINCE, CHINA

TEL/FAX: 0086-576-88800987

EMAIL: info@golden-choice.net

website: www.golden-choice.net



CHOICE[®]
HIGH TECHNOLOGY

注：本册所列产品可能会因改良而有所变动，以随机说明书为标准，恕不另行通知，由于印刷原因，与产品实际颜色可能稍有差异，敬请谅解。

NOTE: Some products information on catalogue may be changed because of improving products, but must be same as instruction which is attached with products. Please forgive that we will not make additional advice in advance. Because of printing question, maybe there is little difference compared with the real color of products. Sincerely sorry for the inconvenience.

CHOICE[®]
HIGH TECHNOLOGY

ABOUT US

For a decade,
we have been upholding the idea that
quality is the strongest weapon to
win the market.

In face of various internal and
external changes,
we will never give up our resolution to
strive for world-class standard products
and pursuit for
development of our heart.

We believe that
Golden Choice will bring
surprise
to all customers
in the near future.

BETTER CHOICE
BETTER
CLOTHING



CATALOGUE

FULL RANGE OF OVERLOCK SEWING MACHINE MATCH YOUR NEEDS

Overlock Sewing Machine	P01-P09
Interlock Sewing Machine	P10-P17
Lockstitch Sewing Machine	P18-P25
Chainstitch Sewing Machine	P26-P27
Heavy & Leather Machine	P28-P36
Zigzag Sewing Machine	P37-P40
Blind Stitch Sewing Machine	P41-P42
Hand Stitch Machine	P43-P45
Multi-needle Sewing Machine	P46-P52
Special & Automatic Sewing Machine	P53-P68
Finishing Equipment	P69-P76
Cutting Machine	P77-P82



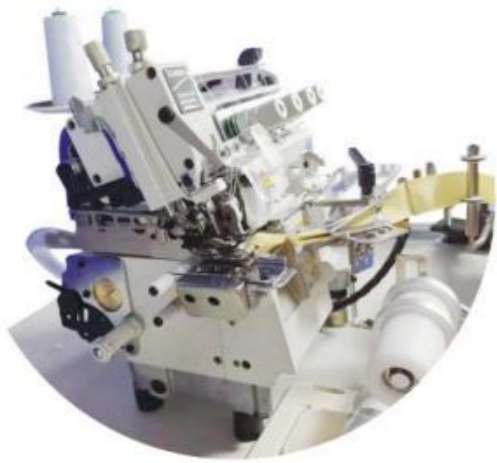

GC5114EXT-D-SRC-4P

Auto collar/ Sleeve attaching overlock sewing machine with tape feeding and attaching device

- ▲Suitable for sewing small-sized tubular goods such as children , baby's clothes and the sleeves of T-shirt
- ▲Forced circulation oiling system assures oil free at the needle bar
- ▲With differential feeding graduator for micro-adjustment
- ▲With the adoption of silicon oil on the thread & needle cooling system, helpful to prevent thread and needle breakage

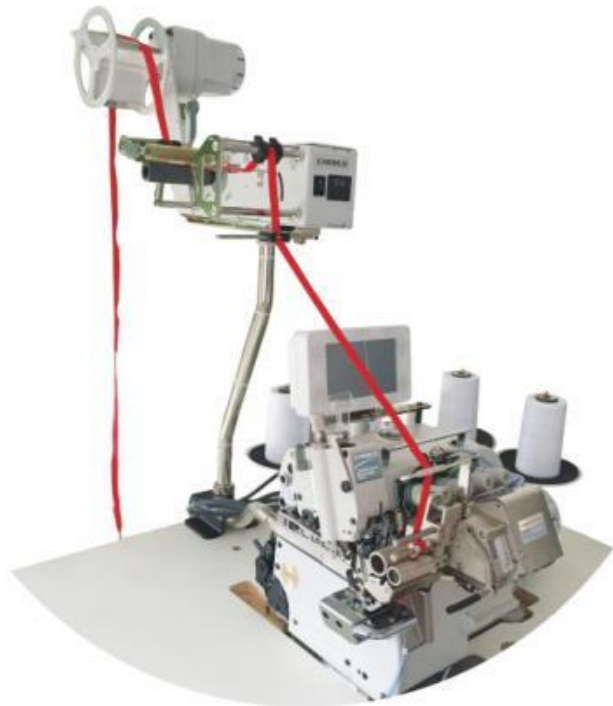

GC3216EX-D-MC

Direct-drive small cylinder bed overlock machine with auto tape cutter & computerized metering device

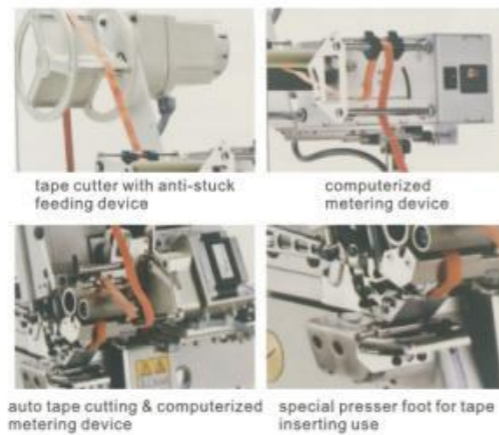

tape cutter with anti-stuck feeding device

computerized metering device

auto tape cutting & computerized metering device

special presser foot for tape inserting use

	!	⚠	!!	🧵	🧶	📏	⚖	🔄	📦	📏
GC5114EXT-D-SRC-4P	2	4	2	3-4-5	3.8	0.7-2.0	5.5	6500	470x365x500	51.3/62.2
GC5114EXT-D-RC	2	4	2	3-4-5	3.8	0.7-2.0	5.5	6500	470x365x500	51.3/62.2
GC3216EX-D-MC	2	4	2	3-4-5	3.8	0.7-2.0	5.5	7000	470x365x500	51.3/62.2
GC5104EX-D-SRC-4P	1	3	2	3-4-5	3.8	0.7-2.0	5.5	7000	470x365x500	51.3/62.2



GC5114EX-D/R

Direct-drive small cylinder-bed overlock sewing machine

- ▲Auto trimmer and auto foot lifter is optional
- ▲Suitable for sewing small-sized tubular goods such as children , baby's clothes and the sleeves of T-shirt
- ▲Forced circulation oiling system assures oil free at the needle bar
- ▲With differential feeding graduator for micro-adjustment
- ▲With the adoption of silicon oil on the thread & needle cooling system, helpful to preventing thread and needle breakage



GC3216EXT-TA/DD

Direct-drive 5 thread top feeding overlock with variable top feed and tape binding for heavy jeans pocket seaming



GC3216EXT-EUT/DD

Direct-drive 5 thread top feeding overlock with variable top feed with auto trimmer and auto foot lifter

	!	⚠	!!	🧵	🧶	📏	⚖	🔄	📦	📏
GC5214EX-4	2	4	2	3-4-5	3.8	0.7-2.0	5.5	7000	470x365x500	27/34
GC3244EX	3	6	2	3-4-5	3.8	0.7-2.0	5.5	7000	470x365x500	27/34
GC5203EX	1	3	—	3-4-5	3.8	0.7-2.0	5	7000	470x365x500	27/34
GC5214EX/EUT/DD	2	4	2	3-4-5	3.8	0.7-2.0	5.5	7000	470x365x500	27/34
GC3216EX/PUT/DD	2	5	5	5	3.8	0.7-2.0	5.5	6500	470x365x500	27/34
GC5214EX	2	4	2	3-4-5	3.8	0.7-2.0	5.5	7000	470x365x500	27/34
GC3216EX-02-250	2	5	5	5	3.8	0.7-2.0	5.5	7000	470x365x500	27/34
GC5214EX-MD	2	4	2	3-4-5	3.8	0.7-2.0	5.5	7000	470x365x500	27/34
GC3216EX-5/GA	2	5	5	5	3.8	0.7-2.0	5.5	6500	470x365x500	27/34
GC5220EX	2	5	5	5	3.8	0.7-2.0	5.5	6500	470x365x500	27/34



S6-3/BKS

omputerized auto trimmed overlock sewing machine with Semi-auto back latch device



presser foot lifting while needle plate tongue moving



needle palte tongue and thread



Semi-auto back latch device

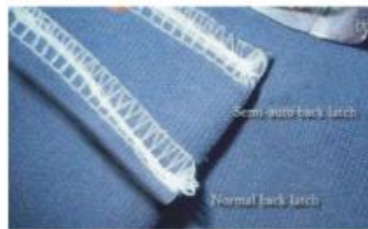
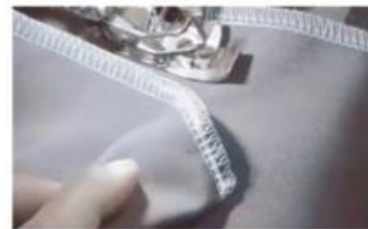

S6-3/BKS	DCX27 #11	1	3	—	8	3.6	0.7-2.0	5.5	6000
S6-4/BKS	DCX27 #11	2	4	2	8	3.6	0.7-2.0	5.5	6000



GC889UT-ACF

Single-head serging unit for trousers and skirts



GC3216EX-3005B-PS

Automatic side seamer

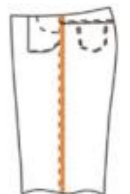

Equipped with seam align device to improve sewing quality
Equipped with Thread Dust Collector
Magnetic Table Easily move for service Purpose
Work Skill Unneeded



Machine Model	GC3216EX-3005B-PS
Machine Head Model	Pegasus MX3216(P)-03/333
Max Sewing Speed	6000sti/min
Needle Type	Dc×1
Max Stitch Length	5mm
Thread Breakage Detection	No
Motor Power	550W
Power Supply	220V
Air Pressure/Consumption	0.5MPa / 5L/min
Machine NW	95KG
Machine GW	191KG
Machine Size	1190×780×1330
Machine Package Size	1870×970×1490



GC5214EX-TW-D
Direct-drive 2 needle 4 thread overlock with tape attaching for overlocking the towels



GC5204EX-82BL
Automatic back latching seaming 3-thread overlock machine auto auto pneumatic trimmer and air foot lifter



GC5214EX-4/EUT/DD
Electronic 4 thread overlock full function with auto-trimmer, auto foot lifter, and direct drive motor.



GC-E52L-R-D
AUTOMATIC LEFT & RIGHT HAND OVERLOCK SEWING MACHINE

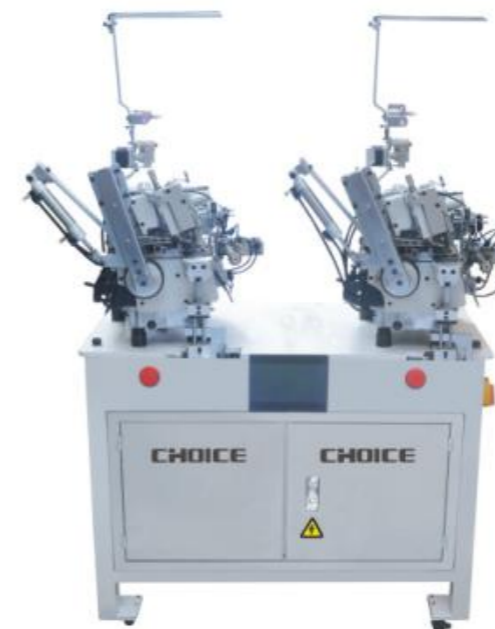

GC-5114EX-GLV
AUTOMATIC GLOVE OVERLOCK MACHINE WITH ELASTIC INSERT



GC737GLV-D
Direct-drive 3 thread glove overlock sewing machine



	!	!!	!!!	!!!	!!!	!!!	!!!	!!!	!!!	!!!
GC5214EXT-4	2	4	2	3-4-5	3.8	0.7-2.0	5.5	6500	470x365x500	51.3/62.2
GC5214EXT-UT/DD	2	4	2	3-4-5	3.8	0.7-2.0	5.5	6500	470x365x500	51.3/62.2
GC3244EXT-TP	3	6	2	3-4-5	3.8	0.7-2.0	5.5	6500	470x365x500	51.3/62.2
GC5214EXT-82BL	2	4	2	3-4-5	3.8	0.7-2.0	5.5	6500	470x365x500	51.3/62.2
GC3216EXT-TA/DD	2	4	2	3-4-5	3.8	0.7-2.0	5.5	6500	470x365x500	51.3/62.2



S6(blue)
All-in-one direct-drive computerized full function overlock sewing machine with speaking and USB function



S61(blue)
All-in-one direct-drive overlock sewing machine



S6(black)
All-in-one direct-drive computerized full function overlock sewing machine with speaking and USB function



S61(black)
All-in-one direct-drive overlock sewing machine



GC6805B/PUT/DD
Computerized pneumatic auto trimming overlock, auto foot lifter, sensor and LED light



S43
All-in-one direct-drive 3 thread overlock machine



S41
All-in-one direct-drive overlock machine



GC747N/DD
Direct-drive overlock sewing machine



S6-T
Intelligent integrated computer overlock sewing machine



GC795-4/DD
Direct-drive overlock sewing machine



GC647KD/EUT
New type direct-drive computerized overlock sewing machine



GC647KD
Direct-drive overlock sewing machine

	Icon 1	Icon 2	Icon 3	Icon 4	Icon 5	Icon 6	Icon 7	Icon 8	Icon 9	Icon 10
S6/S61	2	4	2	3-4-5	3.8	0.7-2.0	5.5	6500	470x365x500	51.3/62.2
S6/S61	2	4	2	3-4-5	3.8	0.7-2.0	5.5	6500	470x365x500	51.3/62.2
GC6805B/PUT/DD	2	5	5	5	3.8	0.7-2.0	5.5	7000	470x365x500	51.3/62.2
S43	2	4	2	3-4-5	3.8	0.7-2.0	5.5	6500	470x365x500	51.3/62.2

	Icon 1	Icon 2	Icon 3	Icon 4	Icon 5	Icon 6	Icon 7	Icon 8	Icon 9	Icon 10
S41	2	4	3	4	0.5-3.6	0.7-2	5.5	5000	470x330x480	33/35
S6-T	2	4	3	4	0.5-3.6	0.7-2	5.5	5000	470x330x480	33/35
GC747N/DD	2	4	3	4	0.5-3.6	0.7-2	5.5	5000	470x330x480	33/35
GC795-4/DD	2	4	3	4	0.5-3.6	0.7-2	5.5	6000	470x330x480	33/35
GC647KD/EUT / GC647KD	2	4	3	4	0.5-3.6	0.7-2	5.5	6000	470x330x480	33/35

NEW



S51N-4

All in one direct drive double needle four thread overlock sewing machine

NEW



GT981X-4(BLUE)

GT series 4 thread high speed direct drive industrial full function overlock sewing machine

NEW



GT998X

GT series high speed computerized industrial full function automatic overlock sewing machine with auto trimmer



GC6704/DD

Direct-drive 4 thread overlock sewing machine



GC700DH-2-250

Pocket seaming overlock for heavy jeans



GC800-5

2 needle 5 thread safety stitch overlock

	1	2	3	4	5	6	7	8	9	10	11
S51N	2	4	3	4	0.5-3.6	0.7-2	5.5	5000	470x330x480	33/35	
GT981X-4	2	4	3	4	0.5-3.6	0.7-2	5.5	5000	470x330x480	33/35	
GT998X	2	4	3	4	0.5-3.6	0.7-2	5.5	5000	470x330x480	33/35	
GC6704/DD	2	4	3	4	0.5-3.6	0.7-2	5.5	5000	470x330x480	33/35	
GC700DH-2-250	2	4	3	4	0.5-3.6	0.7-2	6.0	5500	470x365x500	27/34	
GC800-5	2	5	3	5	0.38-3.8	0.7-2	5.5	6000	475x485x333	27/34	

**EXCELLENT
INTERLOCK MACHINE
WORLD**

CREATE HIGH-CLASS KNITWEAR



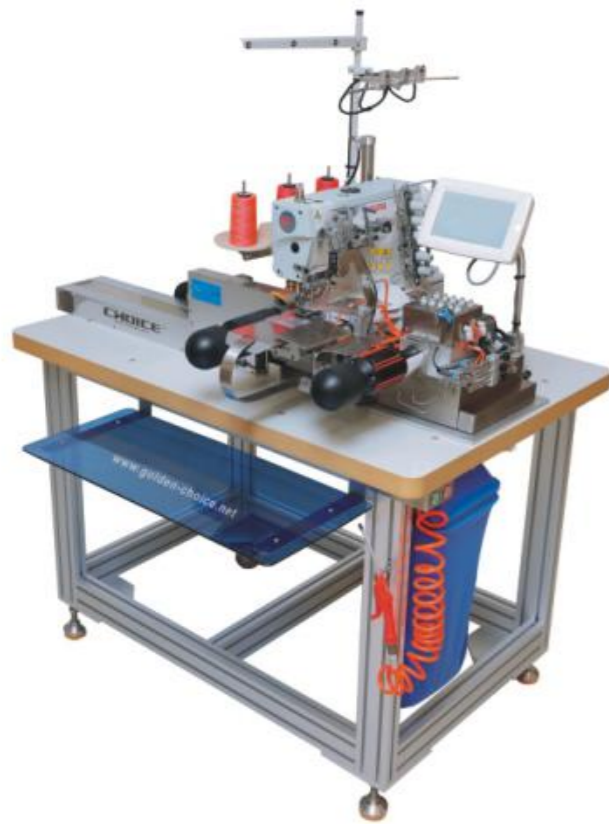

GC-1278P-AT
Full automatic cover stitch bottom hemmer

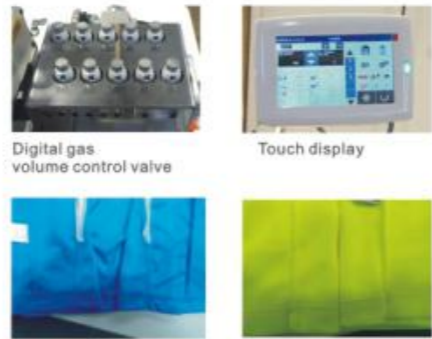

Air Pressure : 0.5-0.6MPa(5-6kgf/cm²)
Machine Head : w3662P-35B-356BSc/UT3T(飞马Pegasus)
Sewing Needle Pitch : 1.00-4.4mm
Max.Machine : Speed 5000rpm
Folding Width : 15-30mm
Sewing Length : 400~800mm (Optional lengthening)
Sewing Time : 10 Seconds/Piece (Depends on the size of the cloth)
Production Efficiency : 2000~2880 Pieces / 8 hours
Machine Dimension : 138(L)x128(W)x 170(H)cm
Gross weight : 230KG

GC-562-BHW
Automatic folding Open type cuff & hem sewing machine



Automatic folding open type cuff&hem sewing device : automatic control , that novices can use a simple operation, uniform high quality and efficiency several times.



GC664-35BB/EUT/DD
Direct-drive auto-trimming computerized cylinder-bed interlock left cutter with air suction device
Pneumatic type trimmer and air foot lifter is optional



GC600D-HG
Auto bottom hemming interlock sewing machine with pneumatic type trimmer and air foot lifter is optional



GC664-33AC/EUT/FT/PR
Cylinder-bed auto electric trimming computerized right-side cutter with rear puller & auto-foot lifter

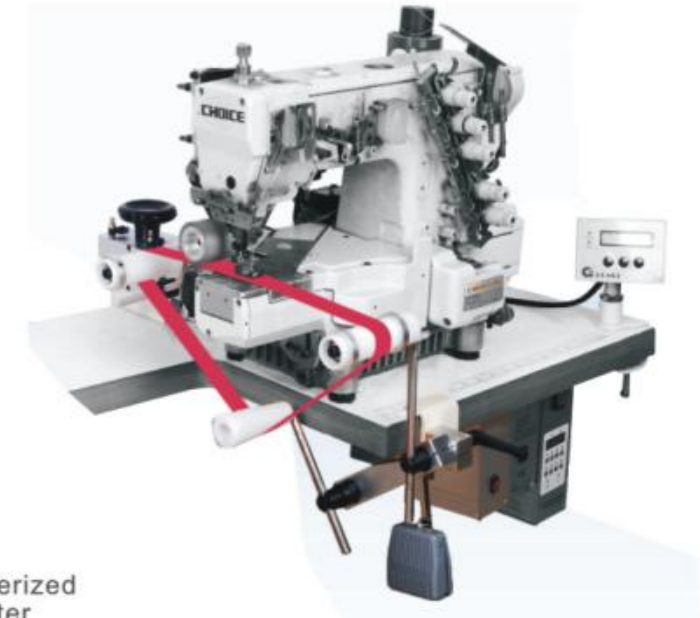

GC664-01CB/PR
Cylinder-bed interlock sewing machine with pneumatic roller tension device

GC664-33AC/PUR/FT/PR
Cylinder-bed auto pneumatic trimming computerized right-side cutter with rear puller & auto-foot lifter

- ▲Attaching flat elastic to tubular goods made of light-medium fabrics, such as the waists of briefs etc.
- ▲Rear puller: rubber puller or gear puller is optional
- ▲The fabric edge trimmer trims the edge of the fabrics during sewing to make a clean finish on the edge of the fabrics



GC664-35BB/EUT/DD	UY128GAS #9- #11	2	4	3.2 4.0	6.3	0.5-1.3	4.4	6000	600X390x630	55/58		
GC600D-HG		3	5	4.8 5.6 6.4	5							
GC664-33AC/EUT/FT/PR	UY128GAS #9- #11	3	5	5.6	5.1	0.5-1.3	4.4	6000	600X390x630	55/58		
GC664-01CB/PR	UY128GAS #9- #11	2	4	3.2 4.0	6.3	0.5-1.3	4.4	6000	600X390x630	49/52		



GC-720T-EST
Direct-drive cylinder-bed interlock machine with auto trimmer



GC787T-EST
Direct-drive cylinder-bed interlock machine with auto-electric trimmer auto foot lifter
Pneumatic type trimmer is optional



GC664-01GB/EUT/DD
Direct-drive Auto-trimming computerized cylinder-bed waistbanding sewing machine mainly for underwear

GC664-01CB
General plain seaming

GC664-01GB
Cylinder-bed waistbanding sewing machine mainly for underwear



GC600-01CB/RP
Cylinder-bed interlock sewing machine with rear puller



for waistbanding



outside type thread cam

Model	UY128GAS #9- #11	3	5	5.6 6.4	7.0	0.8-1.4	1.4-4.5	4500	600X390X630	50/54
GC-720T-EST	UY128GAS #9- #11	3	5	5.6 6.4	7.0	0.8-1.4	1.4-4.5	4500	600X390X630	50/54
GC787T-EST	UY128GAS #9- #11	3	5	5.6 6.4	7.0	0.8-1.4	1.4-4.5	4500	600X390X630	50/54
GC664-01CB/EUT/DD	UY128GAS #9- #11	2	4	2.4 3.2 4.0 4.8 5.6	6.3	0.5-1.3	4.4	6000	670X465X660	55/58
GC664-01CB/PUT/DD	UY128GAS #9- #11	3	5	4.8 5.6 6.4	6.3	0.5-1.3	4.4	6000	600X390X630	49/52
GC664-01GB/EUT/DD	UY128GAS #9- #11	4	5	4.8 5.6 6.4	5	0.5-1.3	4.4	6000	600X390X630	49/52
GC664-01CB	UY128GAS #9- #11	3	5	4.8 5.6 6.4	6.3	0.5-1.3	4.4	6000	600X390X630	49/52



GC1500N-01CB/DD
New type direct-drive plain seaming flatbed interlock sewing machine



GC1500N-01CB/EUT/DD
New type computerized flatbed interlock with auto thread trimmer and auto foot lifter



GC562-FQ
3 function in 1 (General plain seaming, tape binding, cover seaming)

GC562-01CB General plain seaming
GC562-02BB tape binding
GC562-03DB cover seaming



GC562-01CB GC562-02BB GC562-03DB



GC562-01DB
4 needle 6 thread

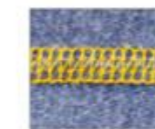

Model	UY128GAS 9-14#	3(2)	5(4)	4.4	3.2 4.0 4.8 5.6 6.4	0.8-2	8	4000	430x284x360	42/47
GC1500N-01CB/DD	UY128GAS 9-14#	3(2)	5(4)	4.4	3.2 4.0 4.8 5.6 6.4	0.8-2	8	4000	430x284x360	42/47
GC1500N-01CB/EUT/DD	UY128GAS 9-14#	3(2)	5(4)	4.4	3.2 4.0 4.8 5.6 6.4	0.8-2	8	4000	430x284x360	42/47
GC562-FQ	UY128GAS #9- #11	2	4	3.2 4.0	6.3	0.5-1.3	4.4	6000	600X390X630	49/52
GC562-01CB	UY128GAS #9- #11	3	5	4.8 5.6 6.4	5	0.5-1.3	4.4	6000	600X390X630	49/52
GC562-01CB	UY128GAS #9- #11	2	4	3.2 4.0	6.3	0.5-1.3	4.4	6000	600X390X630	49/52
GC562-02BB GC562-03DB	UY128GAS #9- #11	2	4	4.8 5.6 6.4	5	0.5-1.3	4.4	6000	600X390X630	49/52
GC562-02BB GC562-03DB	UY128GAS #9- #11	3	5	3.2 4.0	6.3	0.5-1.3	4.4	6000	600X390X630	49/52
GC562-01DB	UY128GAS #9- #11	4	6	6.0	5.5	0.5-1.3	4.4	6000	600X390X630	49/52

GC562-02BB/TK

flatbed interlock with pneumatic tape cutter

GC562B-3

2 needle 3 thread flatbed belt looper



GC562-01DB GC562-02BB Pneumatic tape cutter device



GC562-03FB GC562-01L Long stitch length 7mm GC562-07BB



GC562-08AC GC562-01CB



GC562-05CB

Elastic or lace attaching



Electric type elastic feeding device



GC562-07BB

3 needle 7 thread trousers inner seaming

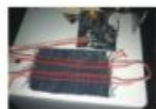

		2	4	3.2 4.0	6.3	0.5-1.3	4.4	6000	600X390X630	49/52
GC562-02BB/TK	UY128GAS #9- #11	3	5	4.8 5.6 6.4	5	0.5-1.3	4.4	6000	600X390X630	49/52
GC562B-3	UY128GAS #9- #11	2	4	3.2 4.0	6.3	0.5-1.3	4.4	6000	600X390X630	49/52
GC562-05CB	UY128GAS #9- #11	3	5	4.8 5.6 6.4	5	0.5-1.3	4.4	6000	600X390X630	49/52
GC562-07BB	UY128GAS #9- #11	2	4	3.2 4.0	6.3	0.5-1.3	4.4	6000	600X390X630	49/52



GC1500-156

Feed-up-the-arm interlock sewing machine

GC1500-156-EUT-D

Direct-drive Auto-trimming computerized feed-up-the-arm type interlock sewing machine

- ▲Applicable to covering seams on all kinds of knit goods collars and cuff, hemming for small-size cuff of trousers and covering & hemming for the wear of children & toddler.
- ▲It can be with upper decoration thread and the stitch is nice



F007KD-W122/EUT/DD

Direct drive auto-trimming computerized flatbed plain seaming interlock with auto foot lifter

C007K-W122

Cylinder-bed general plain seaming



F007J-W122

General plain seaming

C007J-W122

Cylinder-bed general plain seaming

		3(2)	5(4)	4.4	3.2 4.0 4.8 5.6 6.4	0.8-2	8	4000	430x284x360	42/47
GC1500-156	UTY128GAS 9-14#	3(2)	5(4)	4.4	3.2 4.0 4.8 5.6 6.4	0.8-2	8	4000	430x284x360	42/47
GC1500-156-EUT-D	UTY128GAS 9-14#	3(2)	5(4)	4.4	3.2 4.0 4.8 5.6 6.4	0.8-2	8	4000	430x284x360	42/47
F007KD-W122/EUT/DD	UYx128GAS#10	3	5	5.6/6.4	1.6-4.2	1:0.5-1:1.3	5	6000		49/52
C007K-W122	UYx128GAS#10	3	5	5.6/6.4	1.4-3.6	1:0.3-1:2.9	5/7	6000		49/52
F007J-W122	UYx128GAS#10	3	5	5.6/6.4	1.6-4.2	1:0.5-1:1.3	5	6000		49/52
C007J-W122	UYx128GAS#10	3	5	5.6/6.4	1.4-3.6	1:0.3-1:2.9	5/7	6000		49/52

NEW



GC500N-01CB

Direct-drive Plain Seaming Fatbed Interlock Sewing Machine



GC500N-01CB	UY128GAS #9-#11	3(2)	5(4)	4.4	3.2	4.0	4.8	5.6	6.4	0.8-2	8	4000	430x284x360	42/47
GC500N-01CB/EUT/DD	UY128GAS #9-#11	3(2)	5(4)	4.4	3.2	4.0	4.8	5.6	6.4	0.8-2	8	4000	430x284x360	42/47
GC500N-01CB/PUT/DD	UY128GAS #9-#11	3(2)	5(4)	4.4	3.2	4.0	4.8	5.6	6.4	0.8-2	8	4000	430x284x360	42/47

GC6200-04MR/MS-5.2/6.0-D

Direct drive (hohsing servo motor) single or double cutter & air suction device

GC6200DN

New type direct drive (hohsing servo motor) single or double cutter & air suction device

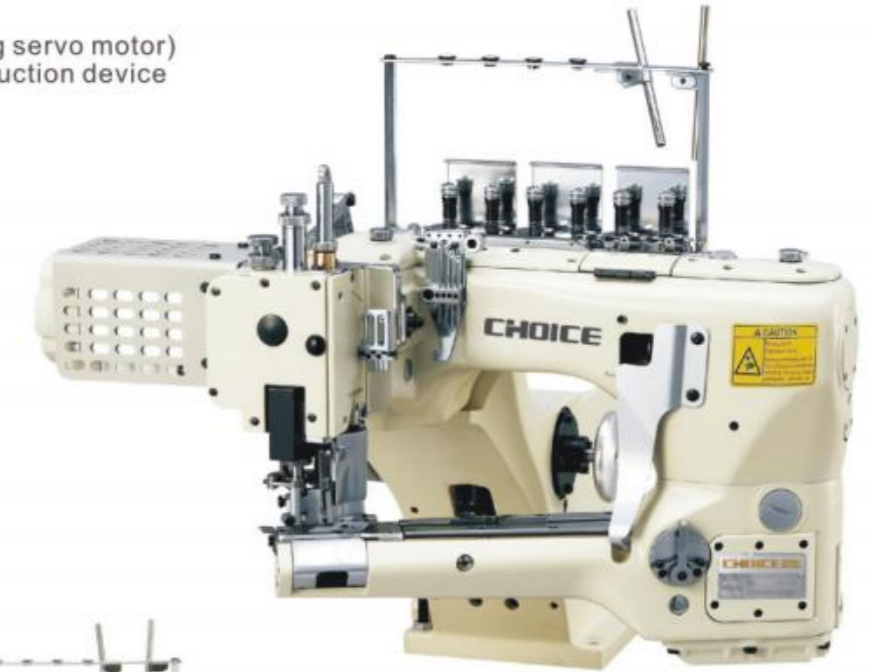

1. This system ensures smooth of various fabric: from single jersey to fleece, stretchable and uneven thickness portion. Besides, overlapping amount of upper/lower fabric is easily adjustable.
2. Small cylinder-bed circumference at the needle dropping point is 148mm. The small cylinder-bed enables small tubular operations. Besides, long cylinder of 200mm before needle dropping point provides a wide operation space.
3. Unique design for tangle free and smooth supply of threads.
4. Easily adjustable for differential ratio by outer lever.
5. Thread tension can be adjusted individually for neat stitch formation.

GC6200-04MR	GBX118 11#	6	5.2/6.0	1.6-2.5	30	6	4000	590x390x490	23/31	
GC6200DN	GBX118 11#	6	5.2/6.0	1.6-2.5	30	6	4000	590x390x490	23/31	

NEW



GC740T-452/460-P

4 needle 6 thread direct drive auto trimmer flat seaming sewing machine, single/double knife, pneumatic auto foot lifter and air suction device

GC740T-452/460-E

4 needle 6 thread auto trimmer direct drive flat seaming sewing machine, single /double knife, electronic auto foot lifter and air suction device

GC740D-452/460-P

Direct drive 4 needle 6 thread interlock sewing machine with pneumatic foot lift and suction device

GC740D-452/460-E

Direct drive 4 needle 6 thread interlock sewing machine with electronic foot lift and suction device



Improved base with large operating space

Integrated structure design impervious oil

Improved wire cutting tool, safe without hand injury

Built-in presser foot, beautiful and quiet (electric/pneumatic)



Completely enclosed wire clip is dustproof and breakage proof

The new type of fully sealed knife rest is designed to prevent oil leakage

All - sealed shell connecting rod can supply oil, quiet and wear - resistant

Direct drive electronic control system

Model	Accessories	Needles	Stitch Length	Stitch Width	Stitch Per Inch	Stitch Per Centimeter	Speed	Dimensions (mm)	Weight (kg)
GC740T-452/460-P	UY128GAS #9-#11	6	3.2-6.4	1.6-2.5	30	6	4000	600x390x630	49/52
GC740T-452/460-P	UY128GAS #9-#11	6	3.2-6.4	1.6-2.5	30	6	4000	600x390x630	49/52
GC740T-452/460-P	UY128GAS #9-#11	6	3.2-6.4	1.6-2.5	30	6	4000	600x390x630	49/52
GC740T-452/460-P	UY128GAS #9-#11	6	3.2-6.4	1.6-2.5	30	6	4000	600x390x630	49/52

BETTER CHOICE
**BETTER
 CLOTHING**



NEW



GC5410N-D4
Needle feed fully automatic computerized lockstitch sewing machine



with voice guide



GC5410N-D3
Needle feed fully automatic computerized lockstitch sewing machine



Auto Presser Foot Lifter (optional)



GC5410X-D3
Single needle needle-feed auto trimmer lockstitch with X-feed (continuous needle-feed)

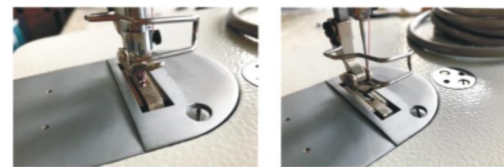

GC5420N-D3
Single needle needle-feed auto trimmer lockstitch machine with side cutter



It is with needle-feeding mechanism and cutter, with the wide range of cutter stroke that even various fabrics's fringe can be neatly cut.

Model	DBX	Needle	Stitch	Speed	Weight	Dimensions	Warranty
GC5410N-D4	DBX1	9#-18#	1	5	5.5-13	4000 720x245x525	38/45
GC5410X-D3	DBX1	9#-18#	1	5	5.5-13	4000 720x245x525	38/45
GC5420N-D3	DBX1	9#-18#	1	5	5.5-13	4000 630x225x550	38/45



GC9000N-D4
(All-in-one) Computerized lockstitch sewing machine full function



R6 button screen, speaking function
R6-T touch screen, speaking function



R2 Direct drive single needle lockstitch sewing machine
R3 Direct drive single needle lockstitch sewing machine with auto trimmer

Model	DBX	Needle	Stitch	Speed	Weight	Dimensions	Warranty
GC9000N-D4	DBX1	#9-#14	1	5	6-13	4000 630x255x555	33.50/38.00
R8X	DBX1	#9-#18	1	5	5.5-15	5000 630x255x555	46
R6	DBX1	#9-#14	1	5	6-13	4000 630x255x555	33.50/38.00
R6X	DBX1	#9-#14	1	5	6-13	4000 630x255x555	33.50/38.00
R2	DBX1	#9-#22	1	5	5.5-13	4500 650x250x470	32-34.5
R3	DBX1	#9-#22	1	5	5.5-13	4500 650x250x470	32-34.5

NEW



R8X
Direct drive single needle lockstitch sewing machine



R6X
Auto trimmed single needle lockstitch sewing machine

NEW



GC8800D
Direct-drive single needle lockstitch

NEW



R7S-T
All-in-one Computerized special stitch pattern lockstitch sewing machine



NEW



R28S-T
All in on double needle lockstitch sewing machine with touch screen and micro oil



NEW



R6N-S1
Oputerized direct-drive all-in-one single needle lockstitch sewing machine

NEW



GC7300
Computerized full function Single needle industrial sewing machine with stepping motor



Model	Needle	Stitch	Speed	Power	Weight	Dimensions
R7S-T	DBx1 7# - 16#	—	6-10	4500	—	0-5 620x290x555 48/45.5
R7S-T-H	DPx5 18# - 24#	—	6-10	4000	—	0-7 620x290x555 48/45.5
R28S-T	DPx5 14# - 22#	—	7-12/≤12	3000	—	0-7 680x290x640 67/59
R6N-S1	DBx1 9# - 14#	—	6-13	4000	—	0-5 630x255x555 33.5/38
GC7300A	DBx1 9# - 14#	—	6-13	4000	—	0-5 630x255x555 35.5/41



GC8700D
Direct-drive lockstitch machine (With needle positioning)



GC8700 / GC8500 / GC5550
single needle lockstitch sewing machine



GC6-9
Single needle heavy duty lockstitch sewing machine



GC202B-D3
Auto-trimmed direct-drive heavy duty lockstitch sewing machine 0-9mm



GC8038
High speed lockstitch lacy sewing machine



GC8088
Pleating lockstitch sewing machine 1 pattern

GC8088-2
Adjustable pleating lockstitch sewing machine 4 pattern



Model	Needle	Stitch	Speed	Power	Weight	Dimensions
GC8700 / GC8500 / GC5550	—	—	4500	0-5	5.5-13	DBX1 9#-22# 650X250X470 32/34.5
GC6-9	8	—	3500	—	6-13	DPX5 22# 575X250X550 25.5/34.5
GC202B-D3	—	—	2800	0-8	5.5-13	DPX17 18#-22# 580X250X530 31/33
GC8038	—	—	1500	5	5.5-13	DBX1 11#-18# 590X230X550 29.5/36.5
GC8088	pleating width 7mm	—	1200	5	5.5-13	DBX1 70#-100# 590X230X550 29.5/36.5
GC8088-2	pleating width 7mm	—	1200	5	5.5-13	DBX1 70#-100# 590X230X550 29.5/36.5



GC8860
single needle lockstitch ruffles sewing machine

GC8860-1
Chain stitch ruffles sewing machine

GC8860-2
Double Chain stitch ruffles sewing machine

01			08		
02			09		
03			10		
04			11		
05			12		
06			13		
07			14		



GC8028
Double colored floral rope lockstitch sewing machine



GC8890
lockstitch sewing machine for thick rope
GC8892
walking foot sewing machine with thick rope

Model	Feature	Speed (rpm)	Needle	Presser	Foot	Dimensions (mm)	Weight (kg)
GC8860	pleating width 7mm	600	4	5.5-13	DBX1 11#-18#	590X230X550	29.5/36.5
GC8028		2000	5	5.5-13	DBX1 11#-18#	590X230X550	29.5/36.5
GC8890		1000	0-9	5.5-13	special needle	590X230X550	25.5/32.5
GC8892		1000	0-9	5.5-13	special needle	590X230X550	25.5/32.5



GC845-D / GC875 -D
Direct drive 2-needle lockstitch small / big hook split needle bar

GC842-D/GC872-D
Direct-drive 2-needle lockstitch sewing machine with small/big hook



GC842-TL
2-needle lockstitch sewing machine with rear puler, the max. needle distance is 48-50mm



GC8420-D4 / GC8720-D4
Computerized 2-needle lockstitch with small/ big hook, auto trimmer & auto foot lifter

GC8450-D4/GC8750-D4
Computerized 2-needle lockstitch with small/ big hook, split needle bar, auto trimmer & auto foot lifter straight/round knife is optional

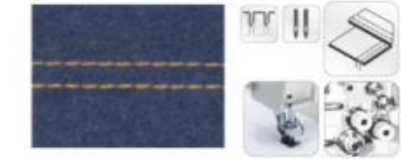

GC8423T
Direct-drive double needle lockstitch sewing machine for waist banding, small hook, flat rear puller , width 36mm, 38mm, 40mm



Model	Needle	Presser	Foot	Dimensions (mm)	Weight (kg)
GC842/8420D/842D-2	DPX5 11#-18#	4	5mm	1/8" 5/32" 7/32"	7-13
GC845/8450D/845D-2	DPX5 11#-18#	4	5mm	1/8" 5/32" 7/32"	7-13
GC872/8720D/872D-2	DPX5 14#-22#	4	7mm	1/8" 5/32" 7/32"	7-13
GC875/8750D/875D-2	DPX5 14#-22#	4	7mm	1/8" 5/32" 7/32"	7-13



GC20518-M/GC20518-B
2-needle needle feed lockstitch small /big hook



GC20528-M/GC20528-B
2-needle needle feed lockstitch small /big hook with split needle bar



GC26518-D3
Auto trimmer computerized double needle needle feed lockstitch sewing machine

GC26528-D3
Auto trimmer computerized double needle needle feed lockstitch sewing machine with split needle bar



GC20518-L-450-FT 1/4", 3/8", 3/16"
GC20518-L-635-FT 1/4", 3/8", 3/16"
long arm 2-needle lockstitch sewing machine with air foot lifter

Model	Weight	Speed	Stitch Length	Stitch Width	Stitch Density	Stitch Length	Stitch Width	Stitch Density	Working Space
GC20518-M / GC20528-M	Medium, heavy	4000	1/8" 5/32" 7/32"	33.4	2	370	630x260x630	47/50	
GC20518-B / GC20528-B	Heavy	4000	3/8" 1/4" 5/32" 1/2"	33.4	2	370	630x260x630	47/50	
GC26518-D3 / GC26528-D3	Heavy	4000	3/8" 1/4" 5/32" 1/2"	33.4	2	370	630x260x630	47/50	
GC20518-L-450-FT / GC20518-L-635-FT	Heavy	2000	3/8" 1/4" 5/32" 1/2"	33.4	2	370	450x150mm 635x100mm	70/79	working space



GC3801 / GC3802 / GC3803
1/2/3-needle chain stitch sewing machine

GC3801D / GC3802D / GC3803D
Direct drive 1/2/3-needle chain stitch

GC3800/RP
Chain stitch sewing machine with rear puller

GC3802/2PL
Chain stitch sewing machine with upper & down puller

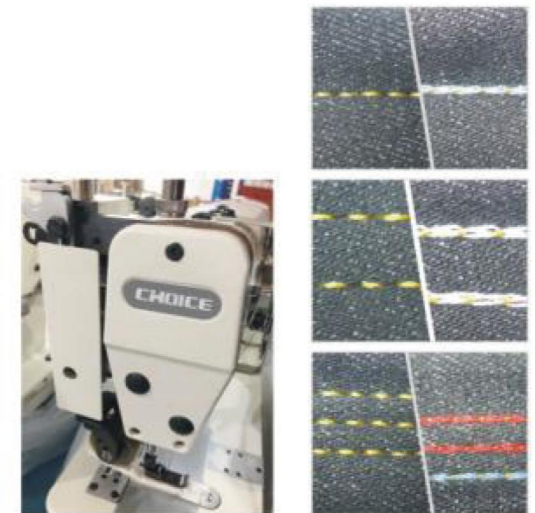

GC3801D/PUT
Direct drive chain stitch sewing machine with pneumatic trimmer



Model	Weight	Speed	Stitch Length	Stitch Width	Stitch Density	Stitch Length	Stitch Width	Stitch Density	Working Space
GC3801 / GC3801D	TV x 7 9#-21#	1	1	2	5/10	4	4500	33/41	
GC3802 / GC3802D	TV x 7 9#-21#	2	2	4	5/10	4	4500	33/41	
GC3803 / GC3803D	TV x 7 9#-21#	3	3	6	5/10	4	4000	33/41	
GC3800/RP	TV x 7 9#-21#	3	3	6	5/10	4	4000	33/41	
GC3802/2PL	TV x 7 9#-21#	2	2	4	5/10	4	4500	33/41	



GC5200-D3
Direct-drive single needle lockstitch auto-trimmer with side cutter



GC5258-PSD
Direct-drive single needle lockstitch auto-trimmer with side cutter & over-edging device, and with air suction device



GC9880B-360-D4
long arm lockstitch(size 360mm), auto trimmer, pneumatic auto foot lifter

GC9880B-560-D4
long arm lockstitch(size 560mm), auto trimmer, pneumatic auto foot lifter

GC9880B-820-D4
long arm lockstitch(size 820mm), auto trimmer, pneumatic auto foot lifter



rear puller is optional

Model	DBX	Needle	Stitch	Speed	Max. Sewing Length	Max. Sewing Width	Max. Sewing Height	Max. Sewing Depth	Max. Sewing Thickness	Max. Sewing Weight	Max. Sewing Length
GC5200	GC5200-D3	DBX1 9#-18#	1	5.5-13	4000	—	—	—	630x225x550	38/45	
GC5258/DD	GC5258/PSD	DBX1 8#-18#	0-5	4-9	5000	—	—	—	630x225x550	38/45	
GC9880B-560-D4		DBX1 9#-18#		6-13	2500-3300	31.8	0-7.5	560 x140	965x325x550	62/70	

NEW



GC5490
Synchronous computer lockstitch sewing machine



GC5490-XT8
Small mouth synchronous computer lockstitch sewing machine



GC5490-H
Synchronous computer lockstitch sewing machine



Big hook



GC5490-7
Upper differential computerized lockstitch sewing machine



GC5490-8XPT
Special lockstitch sewing machine for upper differential tug curtain and home textile



Model	DBX	Needle	Stitch	Speed	Max. Sewing Length	Max. Sewing Width	Max. Sewing Height	Max. Sewing Depth	Max. Sewing Thickness	Max. Sewing Weight
GC5490	DBX17 20#-23#	8	—	—	63	6.5/13	2000	710x290x645	40/37	
GC5490-H	DBX1 14#	0-5	★	★	★	8	5-13	4500	680x245x523	40/50
GC5490-XT8	TVX7 9-14#	0-4	★	★	★	8	5-13	4000	680x245x523	40/50
GC5490-7	DBX1 14#	0-5	★	★	★	8	5-13	4000	680x245x523	40/50
GC5490-8XPT	DBX1 14#	0-5	★	★	★	8	5-13	4000	680x245x523	40/50

NEW



GC5497-XT9

Diferential Computerized Lockstitch Sewing Machine



GC5498

Computerized lockstitch sewing machine for upper sleeves and shirt hem



NEW



GC5593

Top synchronization and bottom differential computer lockstitch sewing machine



GC5593-7

Synchronous up and down differential (quick switch computer lockstitch sewing machine)



GC5499-1

Upper differential chain stitch machine

GC5499-2

Upper differential double needle chain stitch machine



GC5499-8XPT

Lockstitch sewing machine for differential tug chain curtain home textile



drive up and down



GC5594-7

Up and down differential computerized lockstitch sewing machine



GC9980-XC

Differential Computerized Lockstitch Sewing Machine



GC9980-XT6

Small mouth computer lockstitch sewing machine



Model	Needle	Stitch	Stitch Length	Stitch Width	Stitch Density	Stitch Length	Stitch Width	Stitch Density	Stitch Length	Stitch Width	Stitch Density	
GC5498	DBX1 14#	0-5	*	*	*	*	*	8	5-13	4000	680x245x523	40/50
GC5497-XT9	TVX7 9-14#	0-4	*	*	*	*	*	8	5-13	4000	680x245x523	40/50
GC5499-1	TVX7 9-14#	0-4	*	*	*	*	*	8	5-13	4000	680x245x523	40/50
GC5499-2	TVX7 9-14#	0-4	*	*	*	*	*	8	5-13	4000	680x245x523	40/50
GC5499-8XPT	DBX17 20#-23#	8	—	—	—	—	—	63	6.5/13	2000	710x290x645	40/37



GC9270PL 3/16"
2-needle feed-off-the-arm with inner plastic puller



GC9370PL 1/4"
3-needle feed-off-the-arm with with inner plastic puller



GC9280H-2PL
1/4"; 5/16" 3/18"; 9/32"
3-needle feed-off-the-arm with with double puller for heavy material



GC9280-PS
1/4"; 5/16" 3/18"; 9/32"; 1/2"
3-needle feed-off-the-arm with gear-box puller



GC9588XH-PLA-CV-T-MH
3-needle feed-off-the-arm with auto trimmer, direct-drive pneumatic iron puller, servo motor power max motor, auto foot lifter, wooden case



GC9288-2PL/CV
direct-drive 3-needle feed off the arm with auto pneumatic trimmer, auto foot lifter, with double inner puller

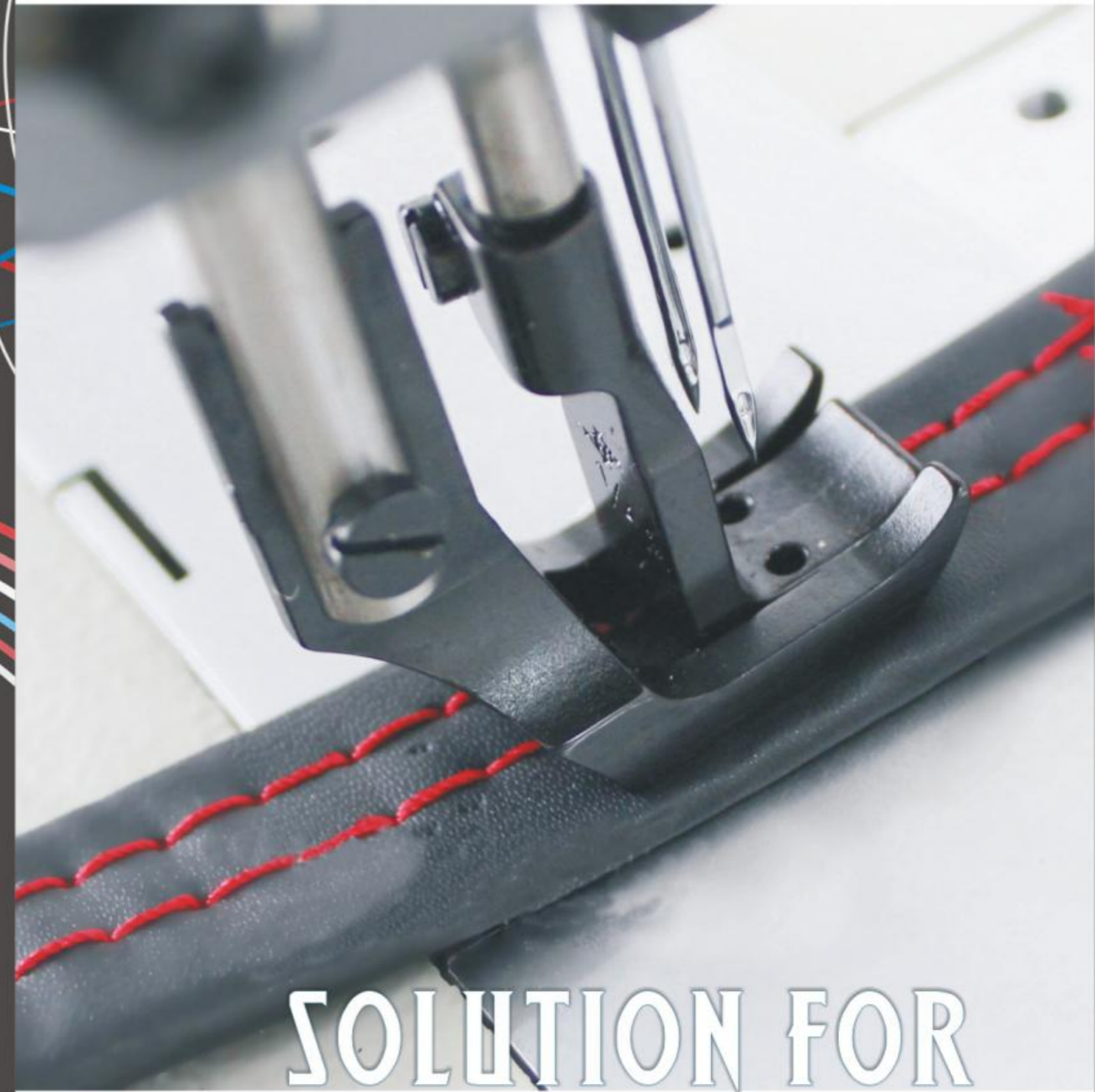

SOLUTION FOR YOUR MAXIMIZED BENEFIT



GC0303D
Direct-drive single needle heavy duty top & bottom feed lockstitch sewing machine



GC0303-D4
Computerized single needle heavy duty top & bottom feed lockstitch sewing machine with auto trimmer & auto foot lifter



GC0303CX
Walking foot with big hook, long stitch length 12mm, thick thread



GC0303B-560-D4
All-in-one Long arm (56cm) direct-drive top & bottom feed lockstitch with auto trimmer, and auto foot lifter



GC640-D3
Computerized auto thread trimmer walking foot lockstitch with auto thread trimmer, 0-8mm, long arm 33cm

	!	±	M	H	⊗	⊕	⊖	⊙	⊚	⊛	
GC0303	GC0303D	DPX17	8	●	●	●	35	8/13	2000	585X260X540	27.5/34
GC0303CX	GC0303CX/D	DPX17	12	●	●	●	35	8/13	2000	585X260X540	27.5/34
	GC0303B-560-D4	DPX17	8	●	●	●	35	8/13	2000	690x230x490	49/51
	GC640-D3	DPX17	8	●	●	●	35	8/13	2000	585X260X540	27.5/34



GC4400B-D4 / GC4420B-D4
Direct-drive compound feed flatbed single/double needle heavy duty lockstitch sewing machine with auto thread trimmer, auto air foot lifter and auto bar tack



GC4400-D4 / GC4420-D4
compound feed flatbed single/double needle heavy duty lockstitch sewing machine with auto thread trimmer, auto air foot lifter and auto bar tack



Gc4400 / GC4420
compound feed flatbed single/double needle heavy duty lockstitch machine 250*100mm



GC2867 / GC2868
single / double needle post-bed compound feed lockstitch sewing machine (left side or right side is optional) , japan hook

GC2868-FT 3/8" 5/16"
with air foot lifter

GC2868-FT-BK 3/8" 5/16"
with air foot lifter and auto back tack



GC4400-L18 long arm 457X100mm, compound feed
GC4400-L25-PFT long arm 635X100mm, compound feed, air foot lifter, functional motor, needle positioning
GC4400-L40-PFT long arm 1016mmx100mm, compound feed, air foot lifter, functional motor, needle positioning

	!	±	⊕	H	⊗	⊕	⊙	⊚	⊛
GC4400	DPX17	6.4	9-16	●	●	●	2000	710x270x680	36/47
GC4420	DPX17	6.4	9-16	●	●	●	2000	710x270x680	36/47
GC4400HL	DPX17	6.4	9-16	●	●	●	2000	710x270x680	36/47
GC4420HL	DPX17	6.4	9-16	●	●	●	2000	710x270x680	36/47



GC-1510-AE

Single needle compound feed lockstitch sewing machine with edge cutter and binding, 0-10mm, operation size: 260x100mm



GC-1510-7 / GC-1560-7

single/double needle computerized (powermax motor) auto trimmed compound feed lockstitch sewing machine 0-9mm, operation size: 260x100mm



GC-1541S

single needle compound feed lockstitch sewing machine with split hook device (with safety mechanism), 0-9mm, operation size: 260x100mm



GC-1565

double needle compound feed lockstitch sewing machine with split needle bar 0-9mm, operation size: 260x100mm



GC-1510L25-7 / GC-1560L25-7

single/double needle long arm 25" computerized (powermax motor) auto trimmed compound feed lockstitch sewing machine 0-9mm



GC-8341(1341) / GC8342(1342)

Cylinder-bed compound feed single needle lockstitch sewing machine with auto trimmer, operation size: 260x100mm



GC-8B

Single needle cylinder-bed compound feed lockstitch machine auto oil lubrication is optional



GC-8B-1

single needle cylinder-bed compound feed lockstitch machine for trousers making up



GC-28BL

double needle cylinder-bed compound feed lockstitch machine



GC-28BL-L20 / GC-28BL-L30

Double needle long arm (500x110mmmm/760x110mm) cylinder-bed compound feed lockstitch machine with auto air foot lifter.

	Icon 1	Icon 2	Icon 3	Icon 4	Icon 5	Icon 6	Icon 7	Icon 8	Icon 9	Icon 10	Icon 11	Icon 12
GC-1510-AE	●	2000rpm	●	9mm	DPX17 18#-25#	36mm	3.2-31.8mm	8/16mm	M/H	260x100		
GC-1510-7 / GC-1560-7	●	2000rpm	●	9mm	DPX17 18#-25#	36mm	3.2-31.8mm	8/16mm	M/H	260x100		
GC-1541S GC-1541	●	2500rpm	●	9mm	DPX17 23#	36mm	3.2-31.8mm	9/16mm	M/H	360x124		
GC-1510L25-7 / GC-1560L25-7	●	2000rpm	●	9mm	DPX17 18#-25#	36mm	3.2-31.8mm	8/16mm	M/H	360x124		
GC-1565	●	2500rpm	●	9mm	DPX17 18#-25#	36mm	6.4-12.7mm	9/16mm		260x100		
GC-8B		DBX17 22# 0-5	★	★	★	★	★	7-10	2800	585x260x525	40/43	
GC-8B		DBX17 22# 0-5	★	★	★	★	★	7-10	2800	585x260x525	40/43	
GC-28BL		DPX17 18#-24#	10	★	★	★	★	8.5-14	2000	working size 258x110mm	40/43	
GC-28BL-L20		DPX17 18#-24#	10	★	★	★	★	8.5-14	2000	working size 760x110mm	85/96	

NEW 867 Series



GC867-110126
Single needle lockstitch industrial sewing machine



GC867-210126
Compound feed computerized flat bed double needle heavy duty sewing machine



GC867-120126
single needle computerized heavy duty fabrics lockstitch sewing machine



GC867-220126
Compound feed computerized flat bed double needle heavy duty sewing machine



Model	Needle	Stitch	Speed	Presser	Table	Width	Height
GC867-110126	●	DP×35 #90-#180	0-20	335-120	750x390x730	70	
GC867-210126	●	DP×35 #90-#180	0-20	335-120	750x390x730	70	
GC867-120126	●	DP×35 #90-#180	0-20	335-120	750x390x730	70	
GC867-220126	●	DP×35 #90-#180	0-20	335-120	750x390x730	70	

NEW 867 Series



GC867-110226
Double needle code single needle lockstitch industrial sewing machine



GC867-210226
Compound feed computerized flat bed double needle heavy duty sewing machine



GC867-120226
single needle computerized heavy duty fabrics lockstitch sewing machine



GC867-220226
Compound feed computerized flat bed double needle heavy duty sewing machine



Model	Needle	Stitch	Speed	Presser	Table	Width	Height
GC867-110226	●	DP×35 #90-#180	0-20	335-120	750x390x730	70	
GC867-210226	●	DP×35 #90-#180	0-20	335-120	750x390x730	70	
GC867-120226	●	DP×35 #90-#180	0-20	335-120	750x390x730	70	
GC867-220226	●	DP×35 #90-#180	0-20	335-120	750x390x730	70	



GC341 / GC342
single/double needle cylinder-bed compound feed lockstitch sewing machine



GC341L-600
GC341L-800
GC341L-1050
Long arm (600/800/1050mm) 1 needle cylinder-bed compound feed lockstitch sewing machine for heavy & extra heavy machines



GC441
Single needle cylinder bed(420mm) compound feed with semi rotary large capacity shuttle for extra heavy materials



GC441L-1300
Long arm (1300mm) 1 needle cylinder-bed compound feed lockstitch sewing machine for heavy & extra heavy machines

	Icon 1	Icon 2	Icon 3	Icon 4	Icon 5	Icon 6	Icon 7	Icon 8	Icon 9	Icon 10	Icon 11	Icon 12
GC341/GC342	DBX17 22#	0-6	★	★	★	★	★	★	8-15	2200	590x315x620	38/42
GC341L-600 GC341L-800 GC341L-1050	DPX17 22#	0-6	★	★	★	★	★	★	8-15	2200	working size 600x100mm	38/42
GC441	DYX3	11	★	★	★	★	★	★	20	2200	590x315x620	38/42
GC441L-1300	DYX3	11	★	★	★	★	★	★	20	2200	working size 1300x100mm	38/42



GC246
Single needle cylinder-bed compound feed lockstitch machine, big hook

GC246-D3 auto trimmer auto-lubrication is optional



GC335A/GC335BL
Single needle cylinder bed compound feed lockstitch machine (small/big hook)



GC810B-D3 / GC820B-D3
All-in-one direct-drive (power max) single / double needle post bed lockstitch machine with auto trimmer



GC9910 / GC9920
Single / double needle roller machine
GC9910D / GC9920D / GC9910
direct drive type with back seaming



GC8365
High-slim post bed single needle compound feed lockstitch sewing machine 445mm



GC591D-BFT / GC592D-BFT
Single / double needle direct drive auto trimmer roller machine



GC-8810P

Single needle compound feed flat-bed sewing machine with wheel feed and driven roller presser

Suitable for high quality normal seam and decorative seam footwear, handbag and leather products etc.



GC-82591-P

Direct-drive flat-bed sewing machine with upper & lower roller feed



GC-550-1780

Double needle post bed Program controlled compound feed sewing machine with rotary needle bar



GC-218G-WXA

Post-bed 360 degree rotation lockstitch sewing machine



GC-781i

Computerized double thread Moccai sewing machine, 550W/220V/380V, pattern optional button, 190kgs



GC4-5

Fur sewing machine for medium & heavy material



GC600

High capacity string lasting heavy duty machine with auto-oil Lubrication (up drawing machine)



GC810A

Leather skiving machine



GC902

Trimming machine for inner lining



GC801D2A

European Leather skiving machine



GC25

Seam opening and tape attaching machine



GC810C

Leather skiving machine(optional:Square / Round head)



GC2972

Shoe patching machine (large hook)



ZIGZAG SEWING MACHINE SERIES



GC20U33 zigzag sewing machine 8mm, light-medium
GC20U53 zigzag sewing machine 8mm
GC20U43 zigzag sewing machine 11mm, medium-heavy
GC20U63 zigzag sewing machine 11mm
GC20U93 Automatic oil lubrication zigzag machine
GC20U23D double needle zigzag



GC20U73
 Computerized zigzag sewing machine
 180 patterns 2step 3 points, 3 step 4
 points, stitch width 9mm
GC20U73D direct drive type



GC457A single needle zigzag 3 step 4 points
GC457B single needle zigzag 2 step 3 points
GC457D double needle zigzag 3 step 4 points



GC1530
 Auto oil lubrication big hook heavy
 duty zigzag machine for leathers
GC1530D direct drive type
GC1530-2 double needle type



GC1580DB
 Direct-drive computerized heavy-
 duty & leather zigzag sewing
 machine (100 patterns 3 step 4
 points, stitch width 9mm, big hook)

	!	Ω	±	±	☑	Ⓛ	Ⓜ	Ⓜ	☑	Ⓜ
GC20U33 GC20U53	DPX5	1800	5	6/10	9	★	★	23/25	550x250x370	23/25
GC20U43	DPX5	1800	5	6/10	11	★	★	23/25	550x250x370	23/25
GC20U63	DPX5	1800	5	6/10	11	★	★	23/25	550x250x370	23/25
GC20U73	DPX5	1800	5	6/10	9	★	★	23/25	550x250x370	23/25
GC20U93	DPX5	2000	5	6/10	11	★	★	23/25	550x250x370	23/25
GC457A GC457B	DPX5	1800	5	6/10	9	★	★	23/25	550x250x370	23/25



GC2150-1
Flatbed lower feed single needle large hook zigzag (1-step/2-step/3-step)
GC2150-2 double needle
GC2150E E-shaped ("E" type)
GC2150B 1-step, auto lubrication, hook differential structure



GC2150M
Cylindrical upper & lower feed large hook zigzag(zigzag binding, 1-step/2-step/3-step)
GC2150MX
Auto lubrication, hook differential structure, zigzag binding)



GC2156-1
upper & lower feed off the arm single needle small hook zigzag sewing machine (1-step/2-step/3-step)



GC2150H
Post-bed single needle large hook zigzag sewing machine (1-step/2-step/3-step, zigzag binding)



GC20U48
pearl pattern lockstitch sewing machine, 1800rpm, servo motor, pear size 4-10mm



GC391 / GC271
zigzag/embroidery sewing machine

GC-351-204

Computerized flat-bed double needle mark sewing machine. 350rpm, foot lifter 10mm, needle gauge 5.5-12mm, operation size: 320x185mm

Including 298 patterns, like T-shaped, X-type, mouth, etc. It uses Durkopp 1500dx3, V415, V462, T-500 or 1.4mm hollow wire, flat wire or decoration line. Application: leather sofa, fabric sofa, leather car seat cover, soft furniture, tents, shoes, bags, jeans etc.

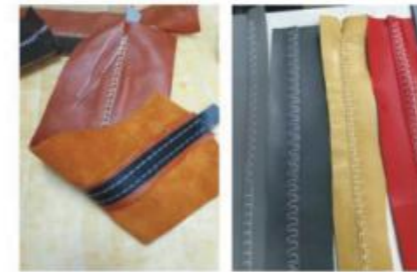

GC-571-T

Computerized post-bed double needle mark sewing machine, 200patterns, 400rpm, 0-12mm, pneumatic foot lifter 22mm, needle gauge 7.94-18mm, shuttle hook, height of sewing post 140mm

It is designed with large-scale and extra-thick duties especially. It has three types of feeding system: double needle, single-needle left-side stitch bed(L), single-needle right-side stitch bed(R). The machine is driven by large power serve motor, adopts long-arm post-bed type and comprehensive feeding with large vertical shuttle hook. Application: tents, sails, umbrella, covers for automobile, protective cover, samouflage net and so on

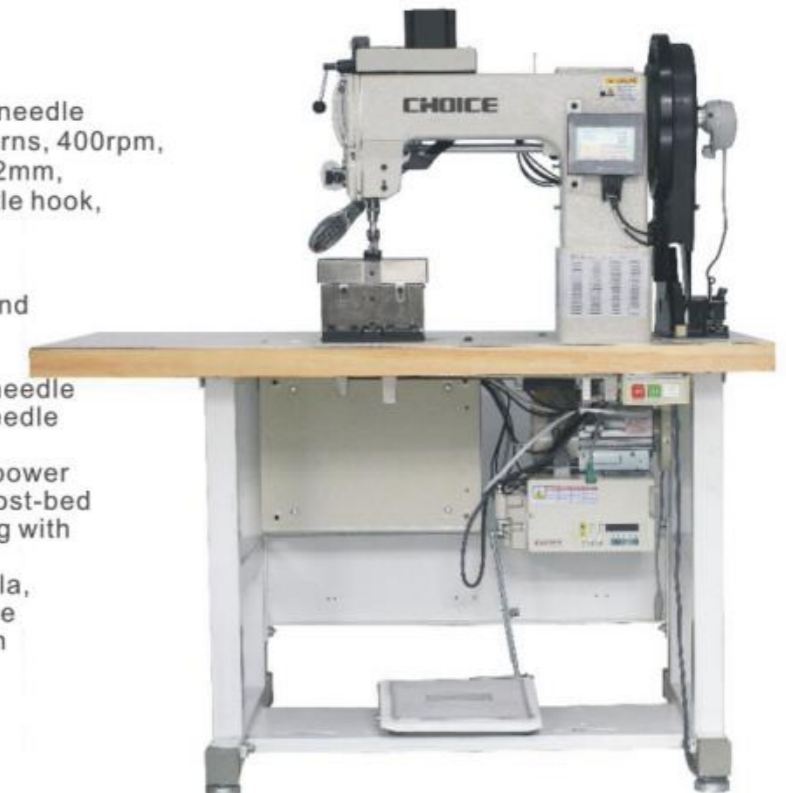



BLIND STITCH SEWING MACHINE



GC502 No Skip blind stitch sewing machine
GC500 Skip stitch for medium material
GC500L-1 Skip stitch for thin material
GC500H-1 Skip stitch for thick material



GC-140
 Clyinter-bed blind stitch machine, suitable for small tube work like socks, sleeves etc.
GC-140H heavy-duty type



GC364 industrial blind stitch sewing machine with differential feeding, suitable for light-heavy material
GC364-BD direct-drive type
GC364-PUT-D direct-drive with pneumatic trimmer



GC101M: Medium-thick
GC101H :Thick industrial blind stitch sewing machine
GC101-D3 with auto trimmer



GC102



GC360 industrial blind stitch sewing machine, suitable for normal trousers and sleeve
GC360D direct-drive type
GC360-PUT-D direct-drive with pneumatic trimmer
GC361 extra-heavy such as wool products
GC362 extra-light material like handkerchief, wedding dress



GC-370-T
 Auto belt loop blind stitch sewing machine with auto ironing device

Model	Motor	Speed	Stitch	Stitch Length	Stitch Width	Stitch Density	Stitch Length	Stitch Width	Stitch Density
GC500 GC502	GCM1 NM65-100 LWX6T 11"-14"	1:1	1:2	5	1200	7	100	400X360X330	11/14
GC101	LWX6T 9"-14"	-	-	8	2500	12	250	490x440x400	20/25



HAND STITCH SEWING MACHINE

Shut Off Air To Adjust Stitch Length
针距变换按钮
Half Stitch Button
半针按钮
Stitch Inversion Button
反点按钮



Adjustment Dial for Pin-point Length
珠点大小调节
Inversion Stitch Lever
调节手柄
Adjustment Dial for Stitch Length
线步疏密调节



GC781-Q Computerized hand stitch sewing machine 0.5mm-6mm

- Applicable for Mens Suit, Ladies Dress, Overcoat, Leather Coat, Regular Fabric, Casual Shirts, Pants, etc.
- 1-needle, 1-thread, real hand stitch machine making pick stitch, saddle stitch, long / short, short / long stitch.
- Stitch length and pin point length can be adjusted easily by turning the dial knob on the machine.
- Thread to be used: Normal thread.
- With the design of bearded shape eye needle, you can load the thread easily.
- Stitch inversion can be controlled by mini switch on the pedal.

Sewing Speed / 缝纫速度	450 s.p.m.
Motor Speed / 马达速度	1,000 r.p.m.
Pin Point Size / 珠点大小	1 - 6 mm
Thread Loading Length / 针线长度	0 - 100 cm
Thread Size / 针线粗细	#80 - #15 (European Standard / 欧标线)
Needle Use / 机针型号	780C
Needle Size / 机针尺寸	#16/#100, #18/#110, #20/#125, #23/#160
Half Stitch Function / 补针功能	Standard / 有
Air Pressure / 气压	6 psi
Gross Weight / 整机毛重	250 kgs
Packing Size / 包装尺寸	105 x 81 x 140 cm (Wooden Case / 木箱包装)



GC781/GC791
Computerized hand stitch sewing machine
0.5mm-6mm with EFKA motor



GC798B
Hand stitch sewing machine 0.5mm-6mm
with EFKA motor, speed 450-500rpm/min,
stitch length 0.5-6mm, needle no.
780C #20, 550W/0.6Mpa/170kg



GC8800H
single needle hand stitch sewing machine
(pitch dead-webbing)

GC8800M
single needle hand stitch sewing machine
(thwartwise dead-webbing)

Model	Speed (rpm)	Stitch Length (mm)	Stitch Width (mm)	Needle	Dimensions (mm)	Weight (kg)
GC8800	1400	0-55	5.5-13	DPX5 75-90	590x230x550	28/36
GC8800H	1400	0-9	5.5-13	DPX5 75-90	590x230x550	28/36
GC8800M	1400	0-9	5.5-13	DPX5 75-90	590x230x550	28/36
GC781A	42-500	0-9	8	16#-23#	760x230x550	28/36
GC791	42-500	0-9	8	16#-23#	760x230x550	28/36



MULTI-NEEDLE CHAIN LOOP SEWING MACHINE



GC1404PMD 4N
Elastic band feeding machine

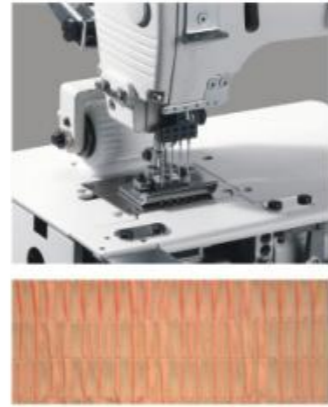

GC1412PQ/GC1433PQ
Elastic thread in the middle, regular thread in the upper and down

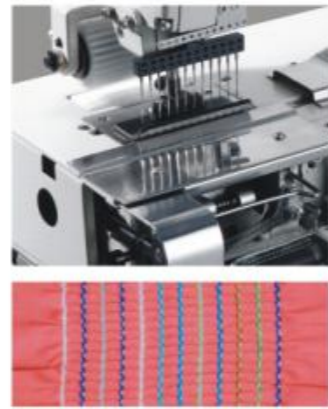

GC1413P
13N double chain loop sewing machine

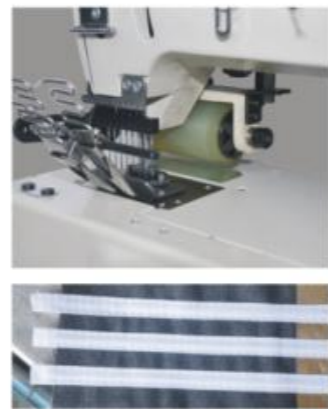

GC-1406PL
6-needle flat-bed double chain stitch sewing machine



GC1412PSM 3/16" 1/4" 12N with shirring
GC1417PSM 3/16" 1/4" 17N with shirring
GC1425PSM 3/16" 1/4" 25N with shirring



GC1412PTV
Back and forth driving double needle chain stitch sewing machine

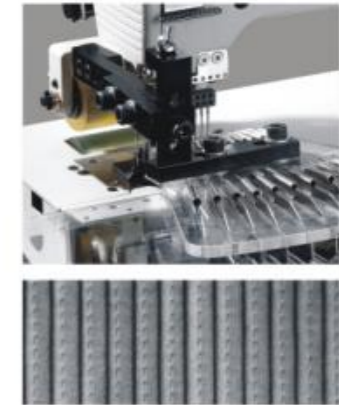

GC-1404PSF
4-needle flat-bed sewing machine for shirt fronting

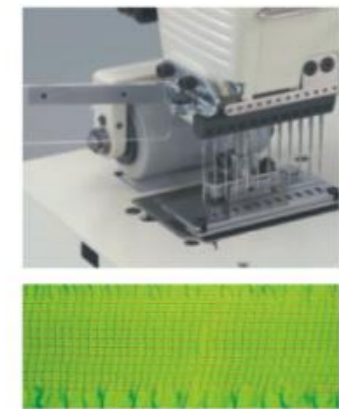

GC-1412PS
12 needles, 17 needles direct drive bottom line elastic cord chains Sewing machine



GC4412P/PUT/PL/DD
Computerized 12N cylinder bed chain stitch machine with auto trimmer and auto foot lifter with roller set



GC1104PRD-D-Y
4 needle 6 thread cylinder-bed double chain stitch sewing machine with needle feed waist banding with Ho Hsing motor

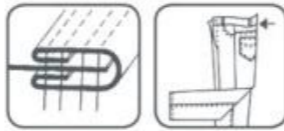

GC1302-4W / GC1803-1S
Double needle 2/3/4 points picot/ facot chain stitch sewing machine



GC2000C
Double needle flat-bed belt loop with front fabric cutter(the width of belt loop 7mm - 20mm)

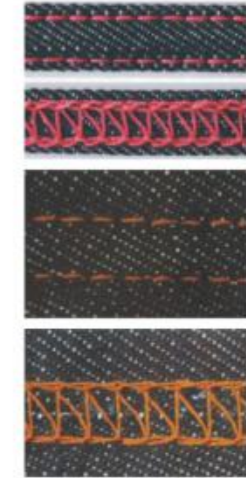

GC1508P
Flat-bed double chain stitch machine with horizontal looper movement mechanism



GC-1721 ficitting sitching machine for the standard setting for making hole stitch, 3-5mm, Guide needle 33.4mm, Main needle : 16.5mm
GC-1721P with the puller device
GC-1721PK with the puller device and cutter device
GC-1721PKAT with puller and cutter device and with auto oiling



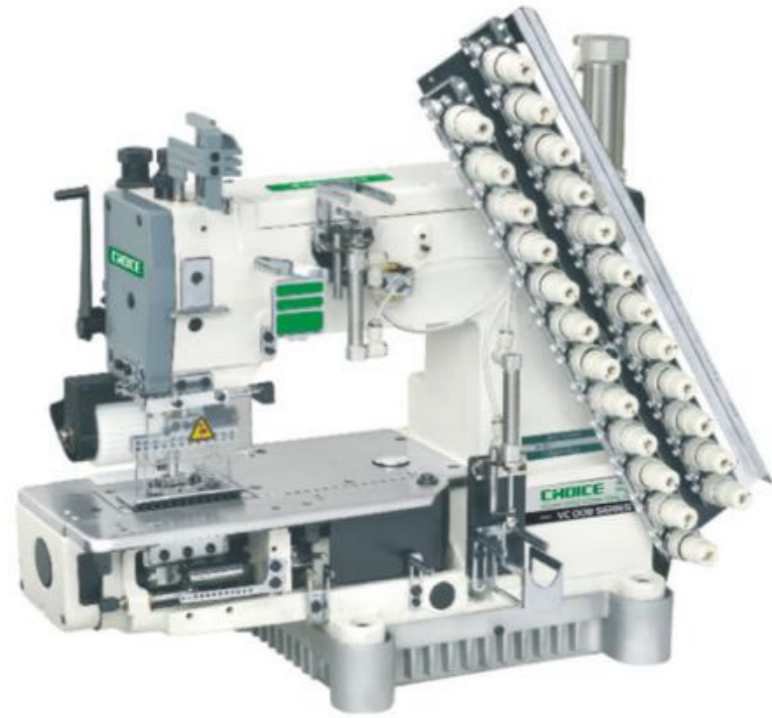

VC008-12064P

12N multi-needle with rear puller double chain stitch sewing machine

Cylinder bed automatic oil, back and forth looper driving mechanism, For general sewing, needle inquiry or gaps can be changed according to desired sewing pattern. suitable for stitching the high-grade clothes.



VC8008-04085P/VCE/VWLB/VSF
4-pin half-cylinder-bed double chain stitch machine



VC8008-08064/VPL
8 needle half cylinder type used for tape attaching

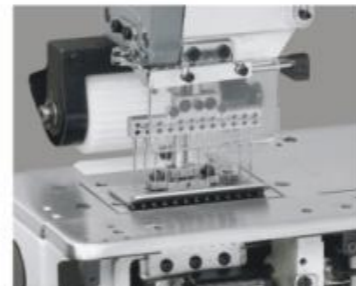

VC8008-12064P/VPS
Multi-needle cylinder bed double Chain stitch machine



VC8008-12064P/VPT
12-needle half cylinder type back and forth Driving double chain stitch machine



VC8008-13032P
13 needle optional needle position For general sewing



VC8008-17048P
Same needle gauge Combined sewing

Model	Needle	Stitch	Stitch Length	Stitch Width	Stitch Density	Stitch Length	Stitch Width	Stitch Density	Stitch Length	Stitch Width	Stitch Density
GC-1302-4W	UOX163 11#	2 3	2X5.55mm	0.8-1.5	8	3500	0.148m ³	41/45			
GC-1302-5W	UOX163 11#	2 3	2X7.40mm	0.8-1.5	8	3500	0.148m ³	41/45			
GC-1412PL	UOX113 14#	12 24	1/4" 3/16"	7-17	10	4000	0.148m ³	53/57			
GC-1412PS-ET	DVX57 14#	12 24	1/4" 3/16"	7-17	10	4000	0.148m ³	53/57			
GC-1412PQ	UOX113 14#	12 36	1/4" 3/16"	7-17	10	2500	0.2m ³	60/64			
GC-1412PTV	DVX57 12#	12 24	1/4" 3/16"	7-17	10	3500	0.2m ³	60/64			
GC-1404PMD	UOX113 14#	4 8	3/4" 1/8" 1" 1/4" 1" 1/2"	8-14	10	4500	0.148m ³	45/48			
GC-1404PSF	UOX113 14#	4 8	3/16" 3/4" 3/16" 1/4" 3/4" 1/4" 3"	7-17	10	4500	0.148m ³	45/48			
GC-1403PSM	DVX57 18#	3 9	1/8"	7-17	6	2000	0.2m ³	53/57			
GC-1425PS-ET	DVX57 14#	25 75	1/4"	7-17	6	2000	0.22m ³	103/107			
GC-1433PS-ET	DVX57 14#	33 99	3/16"	7-17	6	2000	0.22m ³	103/107			
GC-1425PTV	DVX57 14#	25 50	1/4" 3/16"	7-17	10	3500	0.22m ³	60/64			
GC-1433PTV	DVX57 14#	33 66	1/4" 3/16"	7-17	10	3500	0.22m ³	60/64			
GC-1425PQ	UOX113 14#	25 50	1/4" 3/16"	7-17	10	2500	0.2m ³	60/64			
GC-1433PQ	UOX113 14#	33 66	1/4" 3/16"	7-17	10	2500	0.2m ³	60/64			
GC-1425PPDTM	DVX57 14#	25 75	1/4"	7-17	6	2000	0.22m ³	103/107			
GC-1433PPDTMM	DVX57 14#	33 99	1/4"	7-17	6	2000	0.22m ³	103/107			
GC-1508P	TVX5 21#	4 8	1/4" 1" 1/4" 1/4" 3/4" 1/4"	7-16	10	4500	0.148m ³	44/48			
GC-1508PR	TVX5 21#	4 8	3/16" 1" 3/16"	7-16	10	4500	0.148m ³	44/48			
GC-1508PRD	TVX5 21#	4 8	1/4" 1" 1/4"	7-16	10	4500	0.148m ³	44/48			
GC-1503PTF	TVX5 21#	3 6	1/4" 1" 1/4"	7-16	10	4500	0.148m ³	44/48			
GC-1701EHD	UYX128GAS 14-18#	1 2	1/4"	9-12	8	4500	0.148m ³	42/46			
GC-1702	UYX128GAS 11#	2 3	1/4"	9-12	8	4500	0.148m ³	42/46			
GC-1702PMD	UYX128GAS 11#	2 3	1/4"	9-12	8	4500	0.148m ³	42/46			
GC-2000-C	UYX128GAS 14-18#	2 3	1/4"	9-12	8	4500	0.148m ³	42/46			
GC-2000-CP	UYX128GAS 14-18#	2 3	1/4"	9-12	8	4500	0.148m ³	42/46			
GC-4412P	DVX57 14#	12 24	1/4" 1/8" 3/16"	1.4-3.6	8	4000	0.2m ³	47/51			

Model	Needle	Stitch	Stitch Length	Stitch Width	Stitch Density	Stitch Length	Stitch Width	Stitch Density
VC008-12064P/VPQ	12	12	1/4"	1.4-3.6	12	11-14#	1500	
VC008-12064P/PQ	12	36	1/4"	1.4-3.6	12	11-14#	1500	
VC008-12064P/VSQ	12	24	1/4"	1.4-3.6	12	11-14#	1500	
VC008-12064P/VSM	12	36	1/4"	1.4-3.6	12	11-14#	1500	
VC008-08064P/VWL	8	16	1/4"	1.4-3.6	12	11-14#	3000	
VC008-12032P/VPT	12	24	1/8"	1.4-3.6	12	11-14#	3000	
VC008-12048P/VPT	12	24	3/16"	1.4-3.6	12	11-14#	3000	
VC008-12064P/VPT	12	24	1/4"	1.4-3.6	12	11-14#	3000	
VC008-25048P/VPT	25	50	3/16"	1.4-6	12	11-14#	3000	
VC008-25064P/VPT	25	50	1/4"	1.4-6	12	11-14#	3000	
VC008-33048P/VPT	33	66	3/16"	1.4-6	12	11-14#	3000	
VC008-25064P/VSM	25	75	1/4"	1.4-6	12	11-14#	1500	

Button Attaching Series



GC1377
Direct drive button attaching
(cross stitch)

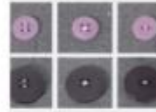

GC373D
Button attaching machine



GC1377D/WP
Direct drive button attaching
with auto thread wiper



GC373D-AT
Direct-drive button sewer with
automatic button feeder



GC373NS
button attaching
for umbrella



GC373NB
button attaching
for label, width
9mm

Model	Buttons	Needle	Presser	Stitch	Stitch Length	Stitch Width	Stitch Density	Stitch Length	Dimensions
GC1377D	⊖ ⊕	TQX7 18#-20#	10-28	>9	8, 16, 32,	1500	24/28	500X300X400	
GC1377	⊖ ⊕	TQX7 18#-20#	10-28	>9	8, 16, 32,	1500	24/28	500X300X400	
GC373D	⊖ ⊕	TQX7 18#-20#	10-28	>9	8, 16, 32,	1500	24/28	500X300X400	
GC373	⊖ ⊕	TQX7 18#-20#	10-28	>9	8, 16, 32,	1500	24/28	500X300X400	
GC1377D/WP	⊖ ⊕	TQX7 18#-20#	10-28	>9	8, 16, 32,	1500	24/28	500X300X400	

Button Attaching Series



GC1900ASS
Electronic bar tacking machine

GC1900D-T
2 function in 1(touch screen)
bar tacking & button attaching

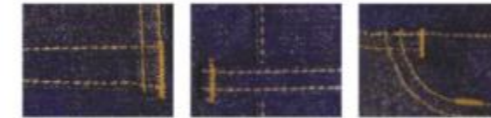

High-speed electronic bar tacking machines,
with 33 kinds of different patterns,
Bar-tacking can prevent the loosening of
thread when finishing sewing.



GC1903D
Electronic button attaching machine

GC1903D-AT
Direct-drive electronic button attaching
with auto button feeder



GC1903D-ACF
Auto-feed button attaching machine



GC4-2
mashroom button attaching, max 20mm
GC4-2-AT
Electronic mashroom button attaching
with auto button feeding system, max 20mm

Model	Needle	Presser	Shuttle	Shuttle Hook	Sewing Size	Stitch Length	Stitch Density	Dimensions	Stitch Length
GC1900ASS	DPX5	14-17	4.2	Standard shuttle hook	30X40mm	0.1-10mm	3000	800×635×515	45/66
GC1902D	DPX17 #14	13	45.7	Standard shuttle hook	Φ8-Φ32mm	0.1-10mm	2700	800×635×515	45/66
GC1903D-ACF	DPX17 #14	13	45.7	Standard shuttle hook	Φ8-Φ32mm	0.1-10mm	2700	800×635×515	45/66

Bar Tacking Series



GC1904D
Pneumatic auto elastic joining bar tacking



GC1905D
Electronic program bar tacking



GC1908D holing bar tacking on cushion
GC1905D program bar tacking Max. size: 50x60mm
GC1904D pneumatic auto elastic joining bar tacking

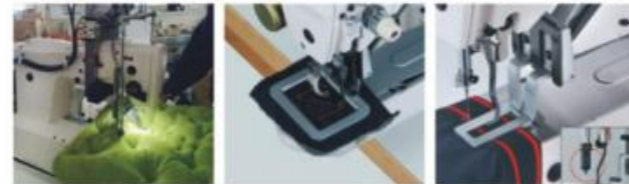

More functions and models:



GC1909D fishing net bar tacking



hole-style bar tacking (no hole in the middle)



Hole-making and bar tacking at the same time

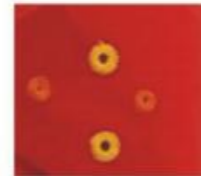

specially for wool products, max. button holing size: 45mm

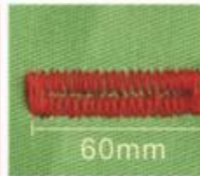

trade mark bar tacking



					sewing size	stitch length			
GC1904D	DPX17 #14	13	45.7	Standard shuttle hook	Φ8-Φ32mm	0.1-10mm	2700	800×635×515	45/66
GC1905D	DPX17 #14	13	45.7	Standard shuttle hook	Φ8-Φ32mm	0.1-10mm	2700	800×635×515	45/66
GC1908D	DPX17 #14	13	45.7	Standard shuttle hook	Φ8-Φ32mm	0.1-10mm	2700	800×635×515	45/66

Bar Tacking Series



GC-1906D-K
Pneumatic thread trimmer suction and bar tacking machine after flat seaming



GC-1906D-Z
Button attaching for Tang suit buttons



GC-1906D-M
Electronic bar tacking and attaching for magic stickers



GC-1906D-T
Electronic elastic joining sewing with touch screen 10*60mm

					sewing size	stitch length			
GC1904D	DPX17 #14	13	45.7	Standard shuttle hook	Φ8-Φ32mm	0.1-10mm	2700	800×635×515	45/66

Button Holer Series



GC9820
Electronic Eyelet Button Holer Machine



9820-00



9820-01



9820-02

The machine is applicable to lock various button holes of formal suits, overcoats, work suits, trousers and jeans of different material thickness.

The world's highest sewing speed 2500rpm enhance productivity.

Beautiful stitches for sewing high-class products.

Large arm pocket allow smooth material handling .

Easy to operate with this computer controlled panel.

Button hole shape is operated by computer, and can be adjusted freely.

Specifications	GC9820-00	GC9820-01	GC9820-02
Thread trimmer	Upper trimmer Lower trimmer	long thread cut none	long thread cut long thread cut short thread cut short thread cut
main applications	ladies' wear	men' s wear, casual' wear	jeans jeans, trousers
other applications	ladie's wear, jeans, trousers	ladie's wear, jeans, trousers	
sewing speed	1. 000-2. 500rpm		
stitch pitch	0.5-2.0mm		
height of work clamp	12mm - 16mm		16mm
needle	DOX558 Nm80-Nm120 (SCHMETZ)		
air pressure	0. 4Mpa Main regulator: 0. 5Mpa , Hammer pressure regulator: 0. 4Mpa		

mm	mm	Stitches/min.	Cut length with eye	Cut length without eye	Memory capacity for buttonhole programs	Number of sewing sequences	Buttonhole programs per sequence
GC- 580	0.5-2.0	2500	6-38	6-38	50	25	9

Nominal voltage	Power consumption	Weight, head only	NL bar	Packaging size (Length, Width, Height)	Core thread Nm	-system	-Nm
V, HZ	KVA max.	Kg	NL bar	mm	Max		Max
1X230V, 50/60Hz	0.5	115	3.0 6.0	1060 750 1100	30/2-120/2	579	90-130

Button Holer Series



GC588-111
single trimmer, 6-50mm

GC588-121
Double trimmer, 6-38mm

GC588-122
Single trimmer, 6-50mm

GC588-112
Double trimmer, 6-50mm
short thread end

GC588-141
Double trimmer, 6-26mm
short thread end, especially for jeans

Scope of sewing:

Buttonhole Length 6 – 50 mm

Diameter of round eyelets 1 – 6 mm

Max. sewing speed 2,700 stitches / min

Product Features

- With wire grabber
- Broken thread fill needles function, to avoid repeat sewing.
- Sewing speed increased from 2200 to 2700, efficiency increased up to 23%
- Large colorful display with touching screen in Chinese and English, to facilitate the programming and operating of all parameters.
- Using the most advanced mechanical engineering design, to reach the perfect sewing effect
- The latest cutting structure and system can adjust the cutting time, which extend efficiency of the cutting knife and make the knife's service life to be longer
- System fully upgraded, reduced single sewing time, greatly improved the sewing efficiency.
- Advanced oil supply system to enlonger equipment life
- Machine automatically retrieve the origin after boot, do not need to rotate handwheel by hand.
- Built-in working light to illuminate the sewing area
- Cut first or cut after sewing
- Semi-submersible machine head to provide a more favorable view and reduce posture fatigue
- Adjustable manual working switch or optional foot pedal working switch



Snap Button Series



GC808
Snap button machine



GC-818
Snap button machine with servo motor



GC-Q3
Three-head pneumatic button machine



GC-SQ1
Single-head pneumatic button machine with Ultraredrays

Icon	Stroke(mm)	Pressure	Fixing time	Icon	Icon	Icon
GC808	38	—	—	1600	312X270X490	18/23
GC-818	38	—	—	1600	312X270X490	18/23
GC-Q3	—	0.4-0.6Mpa	50p/minute	—	440X420X270	26/27
GC-SQ1	—	0.4-0.6Mpa	50p/minute	—	440X420X270	26/27

Automatic Button Machine



GC-20D
Semi-automatic Automatic Button Machine



GC-40D
Full Automatic Button Machine



GC-60D
Full Automatic Button Machine



GC-80D
Full Automatic Button Machine



GC-90D
Full Automatic Button Machine



GC-150D
Full Automatic Button Machine

Model	Power	Voltage	Frequency	Working deep throat	Working height	Working speed	Weight	Packing size
GC-20D	0.75 KW	220 V	50/60 Hz	100 mm	50 mm	180 times/min	74kg	480x480x1200mm
GC-40D	0.75 KW	220 V	50/60 Hz	60 mm	25 mm	180 times/min	82kg	480x480x1260mm
GC-60D	0.75 KW	220 V	50/60 Hz	45 mm	25 mm	180 times/min	120kg	480x480x1480mm
GC-80D	0.75 KW	220 V	50/60 Hz	95 mm	25 mm	180 times/min	110kg	480x480x1320mm
GC-90D	0.75 KW	220 V	50/60 Hz	55 mm	25 mm	180 times/min	100kg	480x480x1310mm
GC-150D	0.75 KW	220 V	50/60 Hz	80 mm	35 mm	180 times/min	165kg	560x830x1260mm

Pattern Sewing Machine



GC1310G-01S

Direct drive procedural computer floral Pattern sewing machine

GC1310G-01A

Direct drive procedural computer floral Pattern sewing machine (pneumatic)

GC2210G-01A

Direct drive procedural computer floral Pattern sewing machine

GC2010

Computer controlled cycle sewing with Input function

GC3020G

Direct drive procedural floral pattern Sewing machine



Computer-controlled and programmed direct drive pattern machine

It is mainly used to sew various mens-wears and women's dress in the apparel industry, denim and knitted fabric, women underwear, bags, shoes and other various applications. Big screen LCD interface, touch screen control new, as long as the fingers touch to complete the man-machine dialogue.

According to the icon and command, easily create sewing data. Sewing data can create one check. You can see at a glance the sewing shape. Increase the speed reduction ratio...counters needles sewing data. Can display eight languages. CF card slot, USB interfaces here standard, by using U disk or card reader, can be realized on a variety of memory (FD, SM, CF, SD, etc.) for data import and export.

Model	★	2	130x100mm	0.05-12.7mm	★	★	2700	1.71L/min
GC1310G-01S	★	2	130x100mm	0.05-12.7mm	★	★	2700	1.71L/min
GC1310G-01A	★	2	130x100mm	0.05-12.7mm	★	★	2700	1.71L/min
GC2210G-01A	★	2	130x100mm	0.05-12.7mm	★	★	2700	1.71L/min
GC2010	★	2	200x100mm	0.05-12.7mm	★	★	2700	1.71L/min
GC3020G	★	2	300x200mm	0.05-12.7mm	★	★	2700	1.71L/min

Belt Loop Attacher Series



GC430D-105APW

Automatic single needle loop attaching machine



GC254-ZD

Double needle automatic belt loop sewing machine

Cutting mode:



Triangle cutting



Flat cutting



- 1, Independent research and development of needle machine can be used to automatically set tab jeans and casual pants ear of a shape, easy to learn equipment operation, saving time and effort. Automatic screening, cutting, folding and tacking processes once completed, and has a simple mechanical construction, easy operation and flexible adjustment, production efficiency.
- 2, The unique design of automatic detection device can filter out waste pants loop joints, and implements automatic filter removal.
- 3, Touch-screen operating system is application to facilitate the management pattern editing and data, operating functions at a glance.

Model	GC254-ZD
Highest sewing speed	2700rpm
Hook	vertical hook of semi-rotary oil feeded by oil-wick
Needle	DPx17#-#21
Thread no	#30-#50spinning line
Number of slitches	operation panel option
Reinforce the sewing pattern memory	standard size 9 designs
Adjustment of stitch	operation panel input mode
Reinforced seam width	1.0mm-3.5mm
Reinforced seam length	5.0mm-22.0mm
Press foot rise in quantity	21mm from needle plate to prate to presser foot
Cloth feeding mode	continuous feed pulse motor drive mode
Sewing machine drive mode	sewing machine dd.acservo motor 550w
Needle distance adjustment method	manual operation rotary hook pulse motor driving model
Belt width	7-20mm
Reinforce sew the belt length	45.0-75mm
Weight	245kg
Power	AC220V
Air pressure	0.5Mpa 1.8L/min

Pocket Attaching Machine

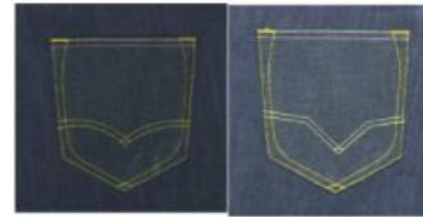

GC6730A-S-AT

Automatic single needle pocket attaching machine, ironing & pressing, for jeans with choice model



GC9000B-AT-2

Full Automatic single needle pocket attaching machine, pneumatic air suction, ironing & pressing, original JUKI model 9000B, mostly for light-medium material

Button Hemming Machine

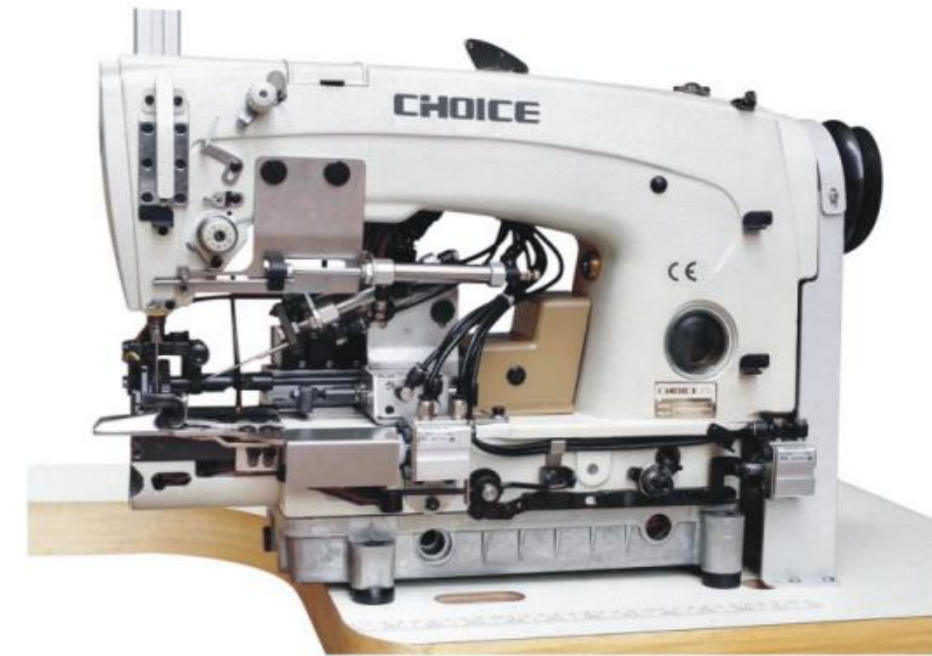

GC63922-D4

Semi-auto single needle lockstitch/chain stitch trouser bottom hemming sewing machine, Ho Hsing motor

GC63922-T-D4

Semi-auto direct-drive single needle lockstitch trouser bottom hemming sewing machine, Ho Hsing motor



Model	Motor	Speed	Stitch Length	Stitch Width	Stitch Density	Stitch Type	Power	Dimensions	Weight
GC-63922	UY 180GVS	1	2.1-4.5	8	1/4 9/23 5/16 3/8 1/2	6	3500	625X400X440	40/30
GC-63922-PF/CV	UY 180GVS	1	2.1-4.5	8	1/4 9/23 5/16 3/8 1/2	6	3500	1230X680X1205	60/40
GC-63922-DH-PF/CV	UY 180GVS	1	2.1-4.5	8	1/4 9/23 5/16 3/8 1/2	6	3500	1230X680X1205	60/40

Automatic Special Machine

Automatic Special Machine

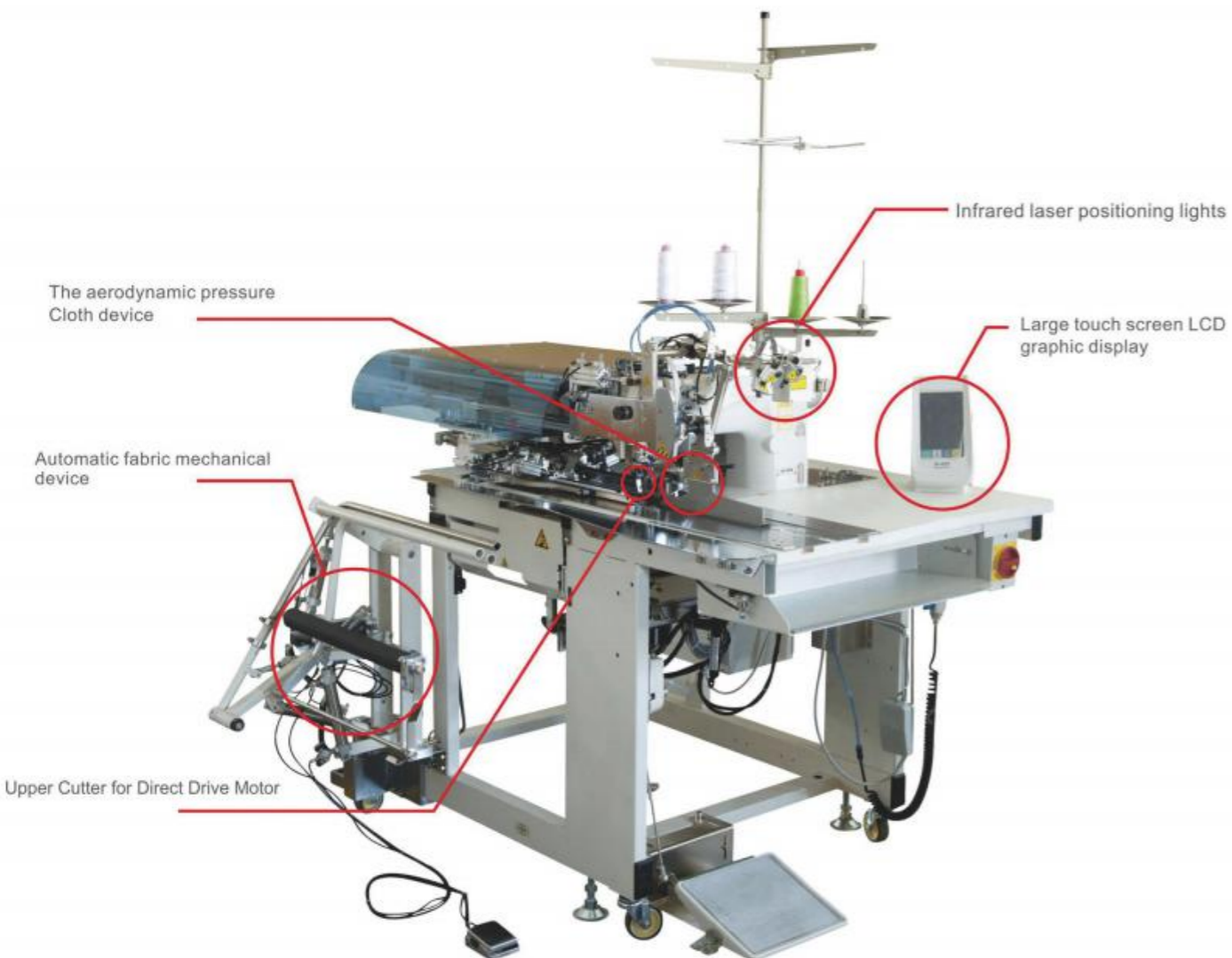

GC-895D-AT

Automatic pocket welting sewing machine(straight pocket)

- Stable performance
- Save time , Save workers
- Automatic multi-function
- Electronic control technology
- Respond to a variety of sewing requirements
- To improve efficiency

The machine supports the sewing of straight pockets (with flaps) on suits, jackets and pants. Double-single-welt sewing can be changed over by the simple touch of a key on the operation panel. The sewing length is extended (35mm-220mm).

The "Upper cutter for direct-drive motor, which transfers the motor power to the machine with no energy loss, not only offers economical benefits due to the power reduction, but also reduces the machine's vibration and operating noise, thereby helping reduce operator fatigue.

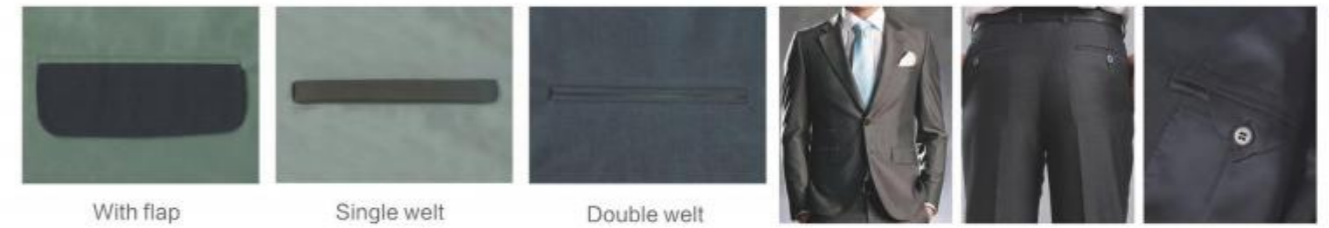

Perormance

- Men suit inner lining pocket: 8 hours can produce 2800 pieces
- Men and women suit with flap and single welt or double welt pocket: 8 hours can produce 2200 pieces
- With triangle flap and inner lining pocket: 8 hours can produce 2200 pieces
- Pocket handkerchief and lattice fabric: 8 hours can produce 2800 pieces
- With flap single and welt or double welt back pants pocket: 8 hours can produce 2200 pieces
- Without flap and single welt or double welt back pants pocket: 8 hours can produce 2800 pieces

Model	Sewing speed	Sewing length	Needle gauge	N.WG.W	Packing size
GC-895D-AT	3000	2.0-3.4mm	10mm 12mm	260/340kgs	146x105x138cm

Automatic Special Machine



GC-A02N
computer placket sewing machine



INTELLIGENT TOUCH SCREEN
micro computer control, intelligent touch screen display simple program, select English language click, there is 2 standard modes: single bilateral placket solution.



Automatic Special Machine



automatic bra-strap sewing robot

GC-300AC

Full automatic bra-strap sewing robot (2 in 1) with cold knife cutting and sewing, head JUKI LK-1900B, standard pattern 50, can store total of a 200 patterns. Strap size: 7-20mm, 20-25mm shall be customerizd. 8 seconds / piece complete a strap size of 400mm

GC-600A

Semi-automatic Bra-Strap Robot(front-single), cold knife cut & sewing

GC-200S(300S)

Semi-automatic Bra-Strap machine (back-single) straps adjustale width 7-24mm, 4seconds/piece

GC-700S

Semi-automatic end buckle Bra-Strap sewing machine

PROCESS:

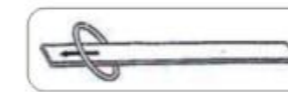

1) Putting the strap through a round buckle



2) Cutting strap in set lengths

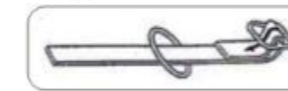

3) Putting the strap through the 8 buckle

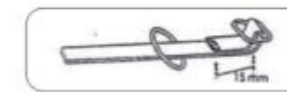

4) Size after completion of sewing



5) putting the strap through the 8 buckle again



6) Finish the strap and stacking adjusted to 50mm



Automatic Special machine



Ultrasonic on Logo Elastic Band Bonding Robot

GC-311U-C

Ultrasonic cut, color sensor

GC-311U-V

Ultrasonic cut, vision system, support nearly-color logo rubber

GC-311U-VS

Ultrasonic cut, vision system, support nearly-color logo rubber, automatic separate size function

- Ultrasonic welding, neat interface without loose edges
- Double alignment device, ensure elastic alignment
- Ironing device
- Separate size production
- Visual system identification LOGO (support near color recognition)
- Automatic counter
- Automatic detection of defective welding
- Disconnected automatically alarm
- Optional flat or overlap



Ultrasonic welding



Sewing

Automatic Special Machine

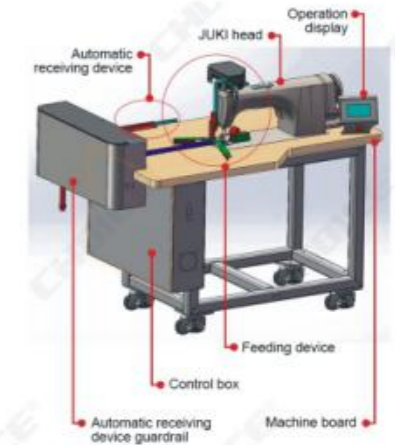

GC9000B-ML

Automatic JUKI head lockstich collar line sewing machine

Intelligent process



Stitch



Collar line

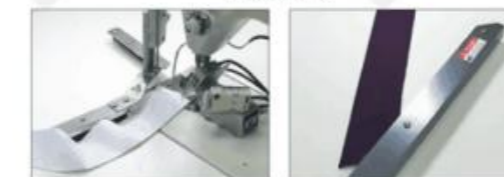

Shirt extreme speed collar line 13 seconds / piece

Perfect trace of specification, Intelligent completion and automatic finishing and receiving of materials at one time, Unskilled and labor-saving, Realize one person to operate multiple machines.

Adaptive collar diagonal function, The edge of the line is consistent with the angle of the line.

Model	GC-9000B-ML
Power	1.0KW
Contour Size	720*1200*1130MM
Working Voltage	220V (50Hz)
Net Weight	150KG

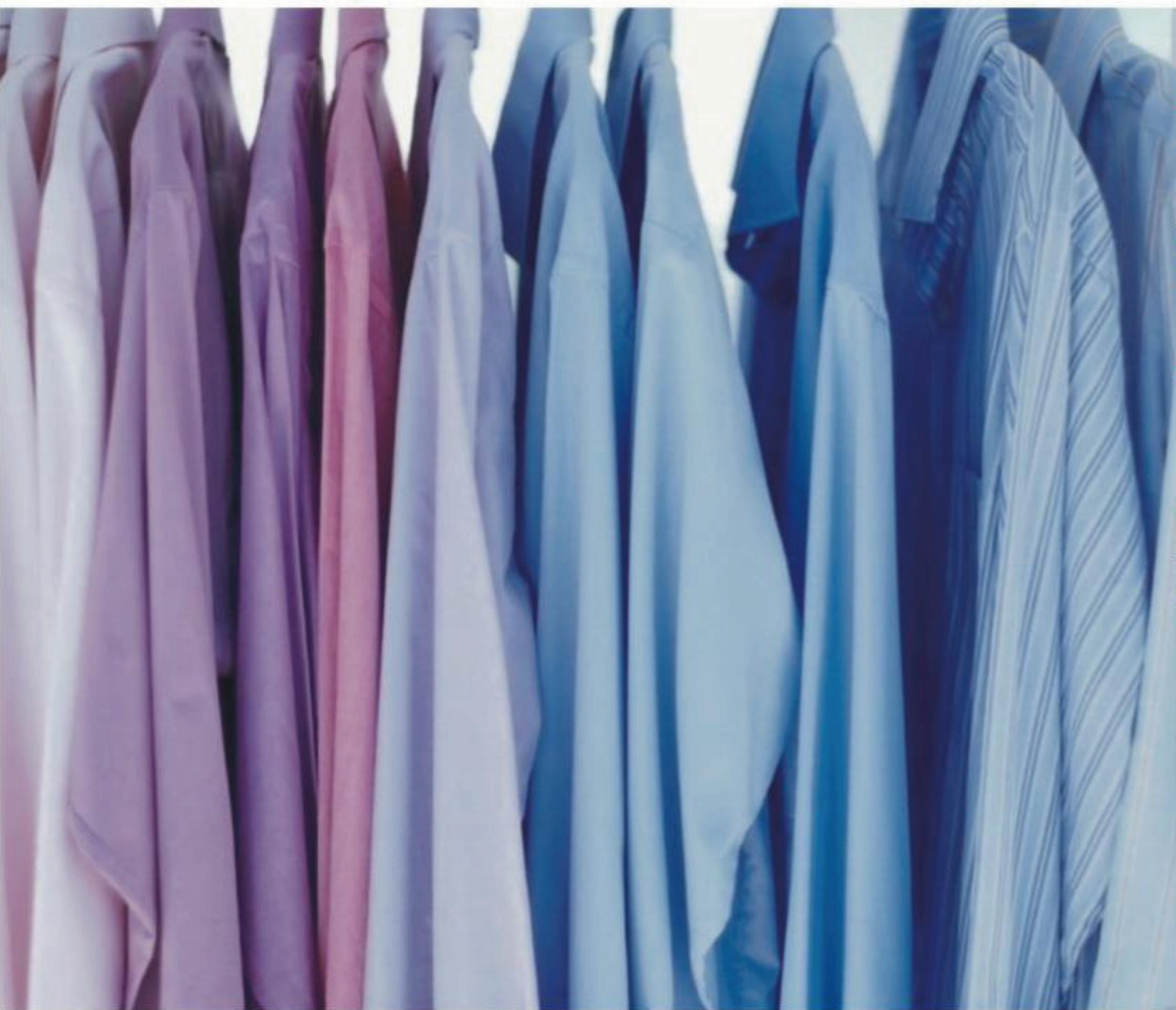

FINISHING EQUIPMENT



GC-46 sleeve cuff machine
1000W/100kgs/0.565cbm
productivity: 2400pcs per 8 hour

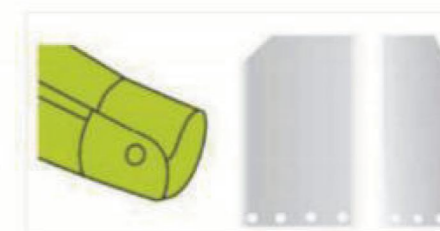

GC-53
automatic collar reversing and steaming
machinery, 2400pcs/8hours



NEW



GC-85

Automatic cuff steaming machinery

Expandable moulding sheet for cuff shaping
 Mechanical hand automatically fixing the cuff position
 Automatic finishing and piling-up after ironing
 Average output volume of 2400 collars / 8hours



Adopt surface clamp for easy tidying the margin

Automatic bottom clamp for avoiding cuff shift during operation



GC-85 袖口模具

GC-85P

Automatic cuff steaming machinery

Pressing shaping the cuff to make it easier for tailor, improving productivity and saving time and energy
 With PLC control, it provides two ways of pressing which meets specific demand for pressing



NEW



GC-81

Collar tip cutting and reverse ironing machinery

Cutting the collar tips and steaming reversely.
 Extra long pressing mould ,suitable for pressing the whole collar Collar position tightly fixed with machine hands,automatic finishing ,and high efficiency.
 Automatic temperature ,pressure ,and pressing time setting output volume of 1800 collars / 8hours .
 Pneumatically operated.



Cut collar

Reverse collar

Press collar

Collect collar



GC-81 领口模具

Model	Voltage	Heat power	Pressing area	N.WG.W	Dimension	Packing size
GC-81	220V/1PH	1000W	-	146/180kg	113x93x130cm	113x93x130cm
GC-85	220V/50HZ	1000W	4x14 inch	153/185kg	85x78x137cm	83x87x135m
GC-85P	1PH/220V/50HZ	1200W	-	162/221kg	80x108x125cm	87x115x140m



GC-92
Collar contour trimmer
220V/50HZ, 1/3PH
dimensions: 92x59x127cm



GC-350
Rotary pressing machine
220V~240V, 50/60Hz
Heater: 2000W
Max. Temperature: 300
Motor: 25W



GC-A1
Model A1 shirt folding table with
electric heating 220V/50HZ
400W/0.4-0.6Mpa/2.2cbm
Mold size: 100-170mm



Fusing machine

GC-F300	Regular fusing machine
GC-F400	
GC-F500	upper conveying width x length 400x1530/ 500x1530 / 600x1530mm
GC-F600	lower conveying width x length 400x1840/ 500x1840 / 600x1840mm
GC-F500S	Seamless regular type fusing belt
GC-F600S	
GC-F450CS	Automatic Fusing machine seamless upper conveying width x length
GC-F500CS	450x1530/ 500x1530 / 600x1530mm lower conveying width x length
GC-F600CS	450x1660/ 500x1660 / 600x1660mm



GC-900SCS

Automatic Fusing machine, air
pressure control upper conveying
width x length 900x2450mm
lower conveying



automatic needle detector

- GC688S**
Single detector 600mm
- GC688S2**
Double detector 600mm
- GC688S1-D**
Single detector 600mm with printer
- GC688S2-D**
Double detector 600mm with printer

Model	Voltage	Heating power	Motor	Operating temperature	Pressure	Belt speed	Fusing width	Packing size	NW/GW
GC-F300	220/380	4	300	0-220	0-5MAX	0-10m/min	300	830x1080x900/0.81	130/180
GC-F400	220/380	4.5	300	0-220	0-5MAX	0-10m/min	400	930x1080x950/0.87	150/200
GC-F500	220/380	5.5	300	0-220	0-4.5MAX	0-10m/min	500	1030x1080x950/1.05	170/220
GC-F600	220/380	6.5	300	0-220	0-4MAX	0-10m/min	600	1130x1080x950/1.15	210/260
GC-F700	220/380	8	400	0-220	0-3.5MAX	0-10m/min	700	1230x1080x950/1.25	220/275
GC-F800	220/380	9	400	0-220	0-3.5MAX	0-10m/min	800	1330x1080x950/1.365	240/300
GC-F900	220/380	10	400	0-220	0-3.5MAX	0-10m/min	900	1430x1080x950/1.47	340/395

Hot Sealing Machine Quotation

NEW



GC-A6



GC-A6+ (with tape feeder)

Three-dimensional wind nozzle positioning system, double stepping motor with horizontal tape feeding motor



Hot Sealing Machine Quotation

NEW



GC-A13+

Super wide space for use, and the platen is detachable. It is more suitable for processing with medium and large tents, car covers and other products



Model	Power	Rated power	Speed	Air Pressure	Roller Width	Tape Width	Lifting Distance	Size	NW
GC-A6	AC 220V 50/60Hz	3.0KW	1~23m/min	0.35~0.5 Mpa	Smooth surface 25mm standard type	Standard type 14mm~25mm	10~30mm	1150×610×1550mm	150kg
GC-A6+	AC 220V 50/60Hz	3.0KW	1~23m/min	0.35~0.5 Mpa	Smooth surface 25mm standard type	Standard type 14mm~25mm	10~30mm	1150×610×1550mm	150kg
GC-A13+	AC 220V 50/60Hz	3.0KW	1~23m/min	0.35~0.5 Mpa	Smooth surface 28mm standard type	Standard type 14mm~25mm	10~30mm	1250×600×1550mm	140kg



TDD-B1
Rectangular electric vacuum ironing table

820x1220mm with arm
820x1520mm with arm
820x1220mm with arm & chimney
820x1520mm with arm & chimney



GC-BJQ3
Banjo type ironing table suction function with light frame



TDG-B1 iron table with boiler



GC-ZA1 Spot remove machine 550W, suction outside size: dia 16.5cm



GC-ZA2 Spot remove machine 550W, suction outside size: dia 16.5cm



M30Q double station heat transfer machine
30X30cm, with six size lower heat plates
30X30cm, 20X30cm, 25X25cm, 17x17cm,
12x12cm, 10x10cm



M4060 Auto pneumatic heat transfer machine, size 40x60cm



GC-M38
Hand hot pressing machine

1. Digital high-accurate control temperature and time
2. Special designed heater, even and precise
3. High-temperature silicon sponge
4. Heating board can be change

Model	Voltage	power	Useful area	temperature	temperature	Packing size	NW/ GW
GC-M38	220	2	38x38	50-220	1-99s	440x750x485	35/38
GC-M50	220	3	40x50	50-220	1-99s	680x750x485	45/51
GC-M62	220	3.2	38x62	50-220	1-99s	680x750x485	45/51
GC-M82	220	4	38x82	50-220	1-99s	880x750x485	65/75
GC-M92	220	4.2	40x92	50-220	1-99s	1020x775x550	75/97
GC-M110	220	4.6	40x110	50-220	1-99s	1200x775x550	85/110



DLD9-0.4-1E
Automatic electric heating steam generator

- 1.High-quality steel
- 2.6KW-18KW multistage pump ; never rest
- 3.High/medium/low water level to choose
- 4.Auto-switch between adding water and heating

Model	Voltage	Heating power	Pressure	Gas production	Start-up time	Packing size	NW/ GW
GC-6-0.4	220/380	6	0.45	9	15	900x860x1490	90/120
GC-9-0.4	220/380	9	0.45	13	12	900x860x1490	90/120
GC-12-0.4	380	12	0.45	17	10	900x860x1490	90/120
GC-18-0.4	380	18	0.45	25	8	900x860x1490	90/120
GC-24-0.4	380	24	0.4-0.5	33	12	900x860x1490	90/120
GC-36-0.4	380	36	0.4-0.5	48	12	900x860x1490	90/120



SZS0.015-0.4-Q
Automatic gas-fired steam boiler,
support for 1-2pcs of iron, single 15kg/h,
220V/50Hz/1Ph



DLD6-0.4-2B3
Automatic electric steam boiler, 6KW,
support for 1-2pcs of iron, 220V/50hz/1phase



GC-T21S/GC-T22S
1/2-head 1/2-knife brushless thread trimmer



GC-35
Electric steam boiler with steam iron



Transparent steamer



GC-94B
Electric iron
209X120mm
1000-1200W



GC-94A/94AL
Gravity feed iron
224X138mm
1300W



GC-85AF
Electric iron
205X124mm
1000-1200W



GC-100-2
Fixed Style(Double-Head) thread trimmer



GC180-F
Thread trimmer for trousers

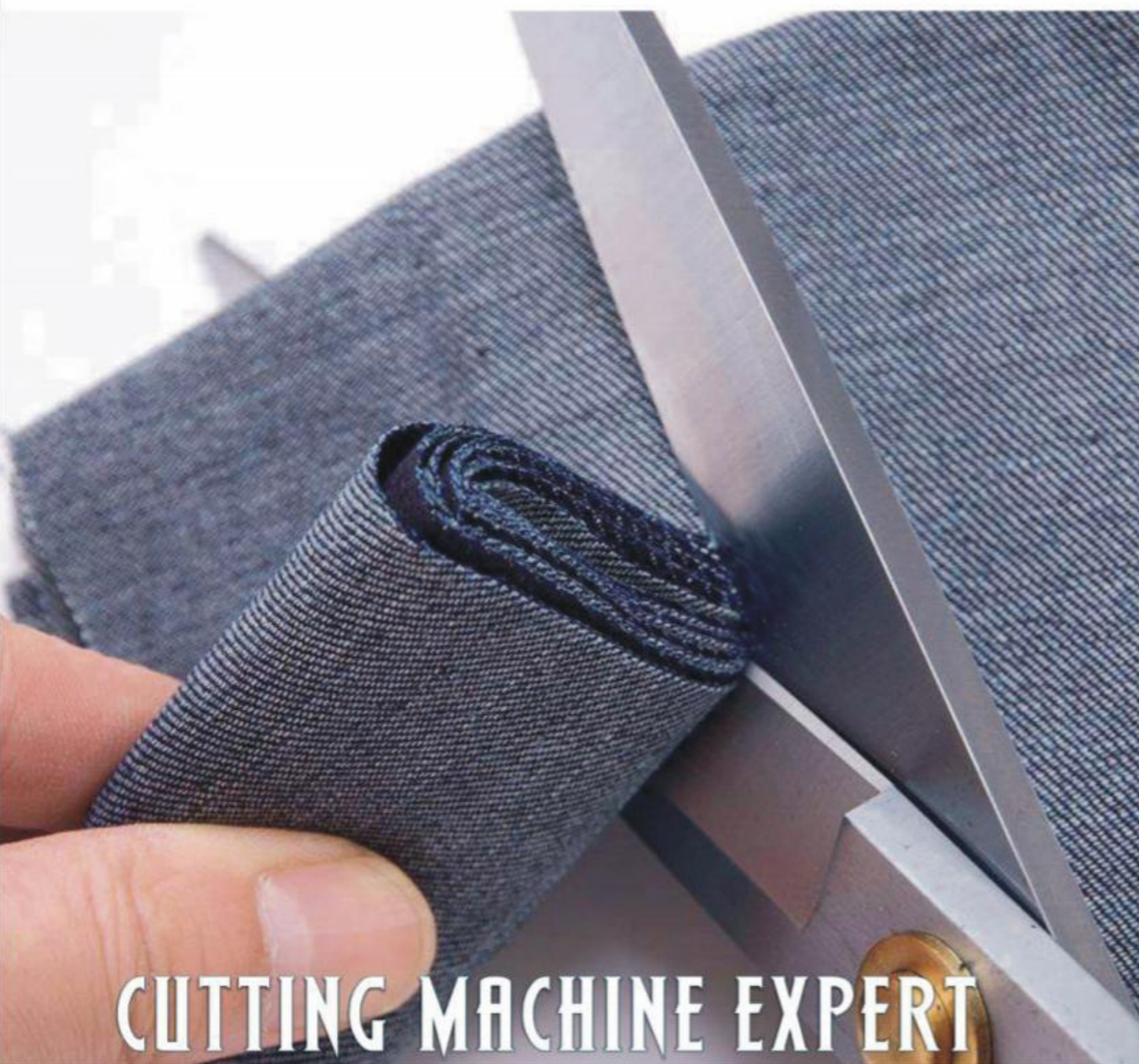

CUTTING MACHINE EXPERT

**GOOD TO THE
GOLDEN CHOICE**



GC900S/1200S Band knife cutting machine



GCD16010 laser cutting machine



DZ-201 8/10"
Heat-controlled driller



GC-40C
4-head thread distributor



GC-20S
2 bobbin thread distributor

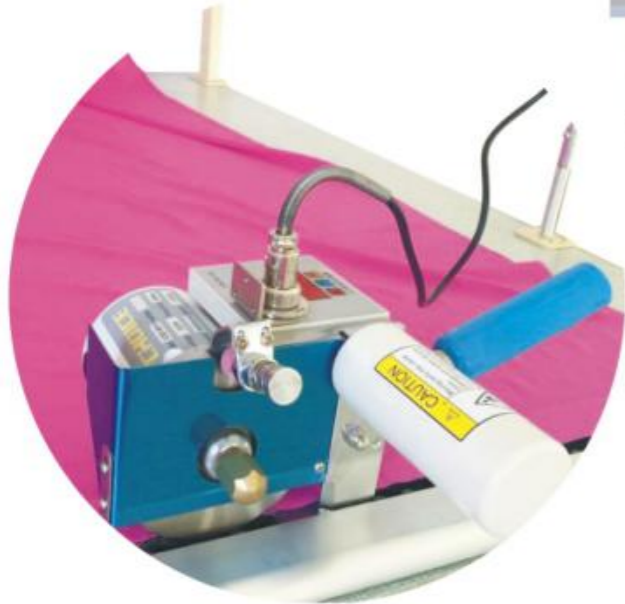

GC-B11 end cutter

Manual end cutter ,the worker need to push the machine forward by manual and it will backward itself.

Long handle or short handle is optional. the machine comes with one rail guide, two rail guide is optional



GC-B12

Automatic End cutter

It is all automatically when cutting the cloth back and forth,reset and lift the rail . It has built-on quick sharpener and protection device of synch-belt disengaging automatically when cutting long materials. it can press the cloth evenly,cut the cloth in neat without missing, count accurately and automatically.



GC KW-190/210

For Woven&knitting fabric
W: 1.6m/1.9m/2.1m



GC KT-190/210

For Woven&knitting fabric
W: 1.6m/1.9m/2.1m



GC-801A Single knife ribbon cutting machine

GC-802A Double knife ribbon cutting machine

Suitable for cutting 45degree bias tape for all kinds Of cloth, the machine function is outstanding. Thin middle and thick cloth all can cut. It is specialized to build for cutting tie-up for the knit fabric. Tie-up the adjustable stanza in a width biggest to 90mm. The rate of cutting speed and the narrow of cloth is random adjustable. It is an ideal equipment to improve cutting cloth efficiency.



GC-911/GC-933

Automatic tape cutting machine

It is suitable for cutting any type of cloth, making it a 45 degree angle strip , widely applied in making suits , shirts , children's wears and T-shirts where strips can be demanded , it has features of high efficiency and high precision.



GC-120H/300M

Computerized tape cutter (hot Knife) with feeding device

GC-120L Computerized tape cutter (cold knife)

High speed: It can cut 100-120pcs per minute
High precision: cutting length is controlled by the stepping motor Cutting in neat :melting & cutting by hot knife , tapes are cut neatly without fraying
Auto operation: it works automatically by setting the cutting length & quantity only
Auto stop: it stops automatically if no more tapes to feed
Memory function: before turn-off, the data of length & quantity setting will not be erased.
Auto feeding device: auto adjust the feeding speed according to the machine work speed. Pre-feeding system to keep constant tension of elastic band
Application: elastic tapes, woven tape, ribbon tape, bag belt nylon tape etc.



GC-812 Tape cutter(cod knife)

GC-815 Tape cutter(cod knife)

GC-817 Tape cutter(cod & hot knife)

It is a mechanical tape cutting machine, for clothing production lines with soft materials, electrical equipment assembly industries. Feeding can arbitrarily adjust the length of the counting function with automatic feed, high efficiency, low noise, small size and light weight, easy to operate and so on. Application to woven tapes, soft tube, string, plastic zipper, small webbing, etc.





Model	Rating Power	Rating Voltage	Cutting Height	Blade diameter	Rotating speed	Weight
RCS-100	3.6-200W	AC 220V±20% AC 110V±20%	27(mm)	100mm	600-800-1000-1200-1400 Adjustable-speed	1.5/1.1
RCS-110	3.6-250W	AC 220V±20% AC 110V±20%	32(mm)	110mm		1.55/1.15
RCS-125	3.6-300W	AC 220V±20% AC 110V±20%	40(mm)	125mm		1.7/1.3
RCS-100B	3.6-150W	DC16.8V	27(mm)	100mm	800-1000-1200-1400-1600 Adjustable-speed	1.7/1.3
RCS-110B	3.6-150W	DC16.8V	32(mm)	110mm		1.75/1.35
RCS-125B	3.6-180W	DC16.8V	40(mm)	120mm		1.9/1.6

Model	Standard	Cutting Height	Power	Voltage	knife Speed	G.W./N.W	Lubricating Oil	Packing Size
CZD-998	8"10"12"	160 210 260 (mm)	1200W	220/110V 50/60HZ	3800/2850(R/min)	18/21(kg)	#18	760x410x320(mm)
CZD-988	8"10"12"13"	160 210 260 285 (mm)	1000W	220/110V 50/60HZ	2850(R/min)	18/21(kg)	#18	760x410x320(mm)
CZD-5	6"8"10"12"13"15"	110 160 210 260 285 335 (mm)	750W	220/110V 50/60HZ	2850(R/min)	17/20(kg)	#18	760x410x320(mm)
CZD-3	6"8"10"12"13"15"	110 160 210 260 285 335 (mm)	550W	220/110V 50/60HZ	2850(R/min)	17/20(kg)	#18	760x410x320(mm)
CZD-103	6"8"10"12"13"	110 160 210 260 285 (mm)	550W	220/110V 50/60HZ	2850(R/min)	18/21(kg)	#18	720x390x300(mm)
CZD-108	5"	90 (mm)	370W	220/110V 50/60HZ	2850(R/min)	9/10(kg)	#18	530x320x232(mm)
DRJ-A200	18"24"28"30"32"	500 600 720 760 810 (mm)	750W	220/110V 50/60HZ	—	13/16(kg)	#18	1060x365x270(mm)

Model	Rating Power	Rating Voltage	Rating Frequency	Cutting Height	Blade diameter	Rotating speed	Weight	Packing Size
RC-120	350W	110/220V	50/60 Hz	40 (mm)	125mm	700rpm	8/10	445x370x250(mm)
RC-125	350W	110/220V	50/60 Hz	40 (mm)	125mm	700rpm	4/4.75	458x263x177(mm)
RC-110	245W	110/220V	50/60 Hz	30 (mm)	110mm	700rpm	3.2/4.2	570x370x467(mm)
RC-100	245W	110/220V	50/60 Hz	25 (mm)	100mm	700rpm	3.0/3.8	570x370x467(mm)
RC-90	200W	110/220V	50/60 Hz	25 (mm)	90mm	1200rpm	2.2/2.8	725x320x300(mm)
RC-70	170W	110/220V	50/60 Hz	25 (mm)	70mm	2000rpm	1.4/1.7	350x320x530(mm)
RC-65	150W	110/220V	50/60 Hz	22 (mm)	65mm	2400rpm	1.2/1.4	620x320x260(mm)
RC-50	80W	110/220V	50/60 Hz	10 (mm)	50mm	2400rpm	1/1.3	320x260x395(mm)
WD-2	150W	110/220V	50/60 Hz	22 (mm)	65mm	2400rpm	1.2/1.4	320x260x395(mm)
WD-1	56W	110/220V	50/60 Hz	10 (mm)	50mm	2400rpm	1/1.3	320x260x395(mm)